

PARTS LIST

HYDRAULIC REVERSIBLE
COMPACTOR

MVH-R60/R60A

405-06301

MIKASA SANGYO CO.,LTD.

PARTS REMARK INDEX

How to read the marks and remarks used in this parts book.

Section 1 : Explanation of Code Use In “MRK” Column

OO : Interchangeable between the new part and the old one.

XX : Not Interchangeable between new and old.

OX : New part is usable for the old machine but the old part is not usable for the new machine.

XO : The old part is usable for the new machine but the new part is not usable for the old machine.

Note : In case of the lack of interchangeability between the new part and old part, a new part may be used by replacing all other parts found in the assembly. In this case, refer to section 2 for instruction on identifying other parts involved in a new assembly.

AD : Newly established(added)

DC : Suspended(discontinued)

NC : Part number changed

QC : Quantity used has been changed

NS : Not supplied individually but supplied in an assembly or a group.

AS : Special part designed to allow interchangeability between new and old part.

CR : Correction

Section 2 : Items Found In “Remark” Column

Serial Numbers — Where indicated, this indicates a serial number range (inclusive) where a particular part is used.

Model Number — Where indicated, this shows that the corresponding part is utilized only with this specific model number or model number variant.

or * : All parts with the same number following # or * belong to the same assembly. this part cannot be interchanged individually with any other assemblies to replace an old part (indicated by #), with a new part(indicated by *), then all other parts of that assembly must be replaced with new ones.

Note : If more than one of the same reference number is listed, the last one listed indicates newest(or latest)part available.

Section 3: Example

REF NO.	PART NO.	PART NAME	QTY	MRK	REMARKS
457(1)	5122-09230	Hinge Metal, Upper/24g	1		-1070 #3 (5)
457(2)	5072-09420	Hinge Metal, Upper M16	1	OX(3)	U1071-(6) * 3(7)

(1) Old part

(2) New part

(3) New part usable with old machine, but old part not usable with new machine (reference section 1).

(4) Old part number is used through this machine serial number.

(5) Old part, used in an assembly with other parts marked with #3. To use this part on a new machine, all other parts in this assembly must be replaced with old ones.

(6) New part put into use starting with this serial number and is still current.

(7) New part used in an assembly with other parts marked * 3, to use this part as a replacement for an old part, all other * 3 marked parts must be changed at the same time.

Section 4: Items Found In “MK2” Column

(only for suspended products)

! OO (“OO” is shown in figure) : The part shown in lower line is supplied.

! SD : Not available due to termination of production.

! NS : Not supplied individually, but supplied in an assembly or a group.

! PD : Supplied as unit product.

SS : Not available after stock run out.

(The contents of this parts catalog are subject to change without notice.)

MVH-R60/R60A/R60L
VIBRATING PLATE

4 L J

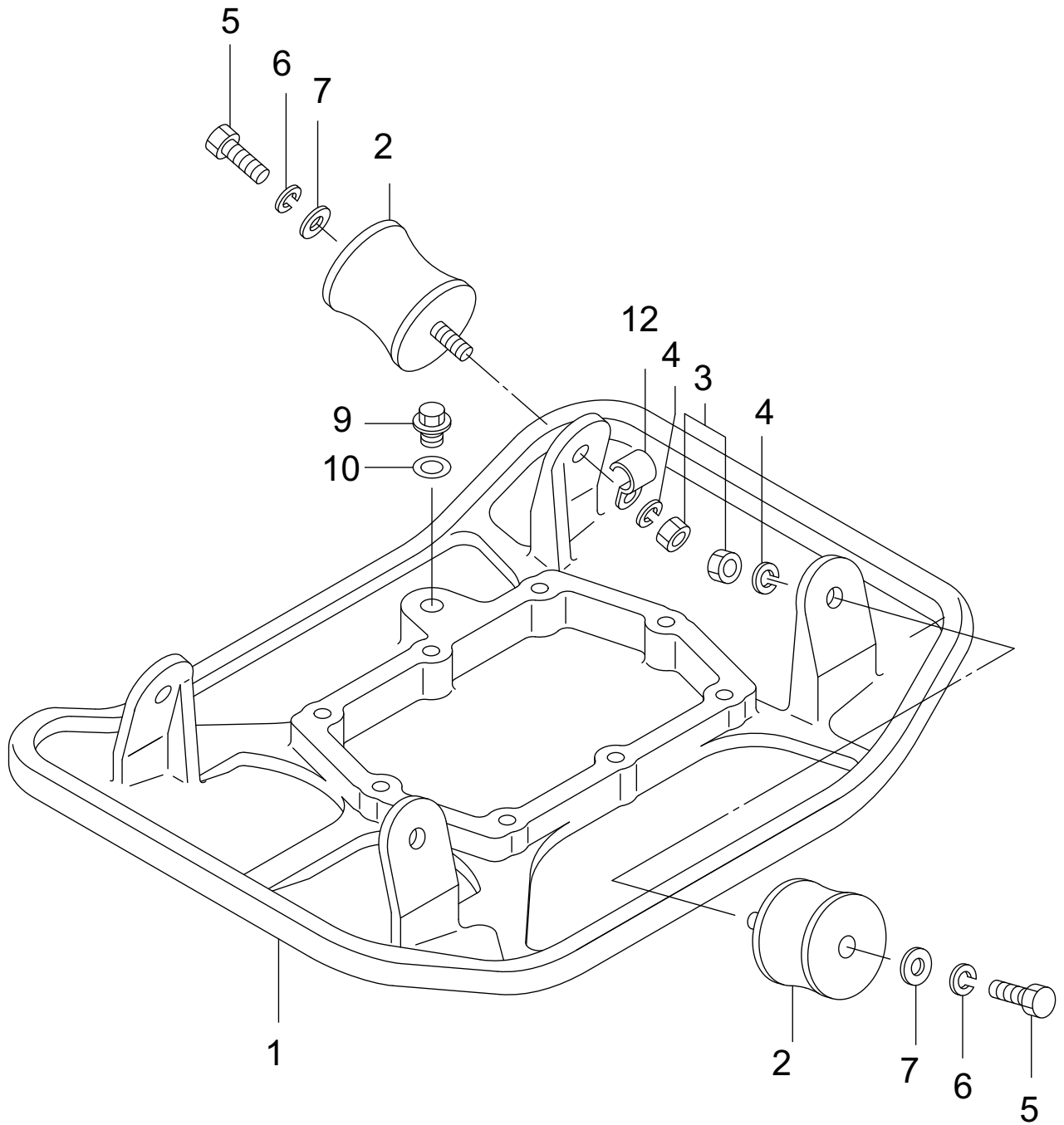

MVH-R60/R60A/R60L
BODY

4LK0

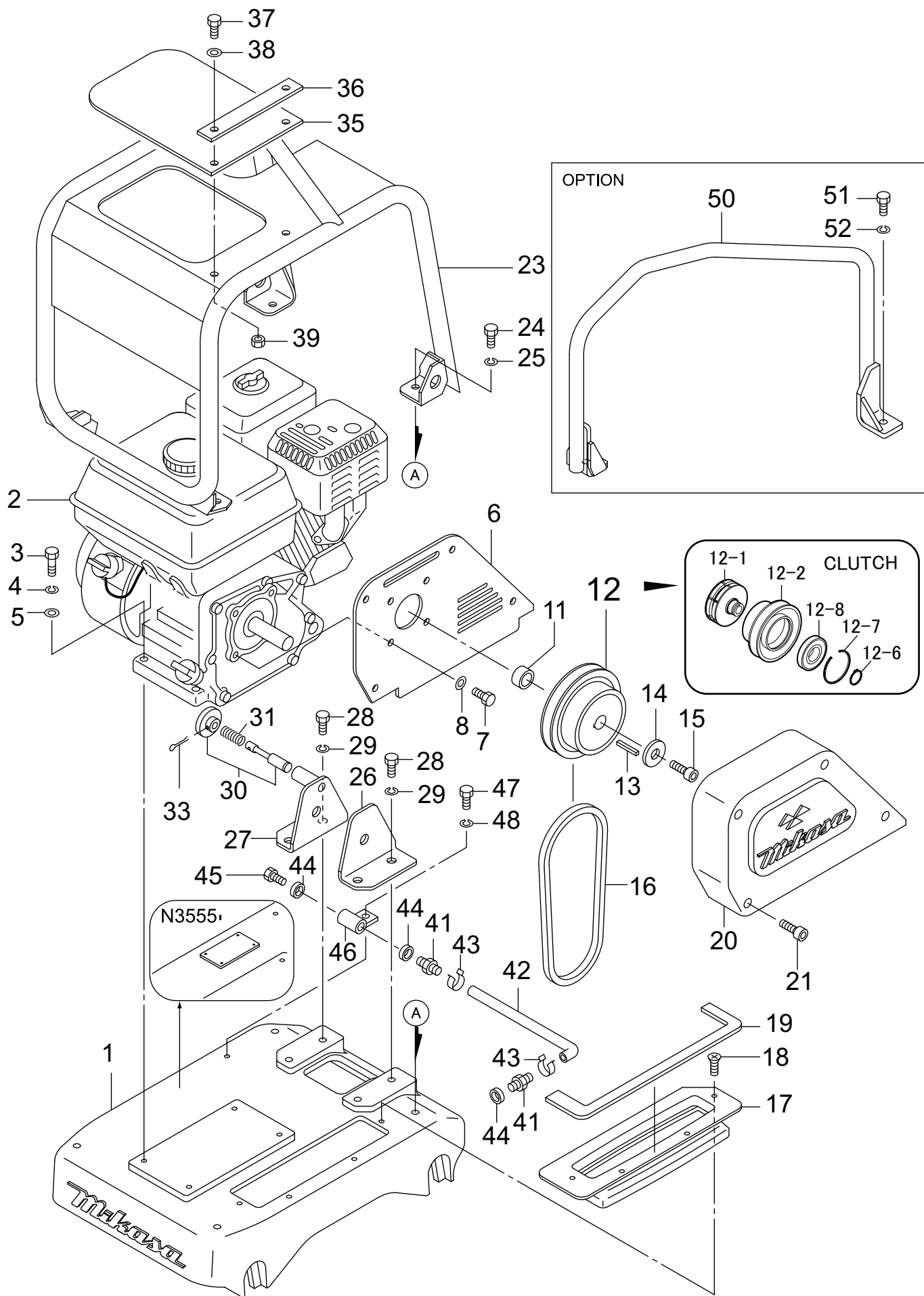

BODY

** 4LK **

REF NO.	PART NO.	PART NAME	Q' TY	MRK	MK2	REMARKS
1	4631-17120	BASE /MVH-R60	1	DC	!4631	#1
1	4631-17121	BASE (M12)/MVH-R60	1	XX	!4631	*1, #5
1	4631-17122	BASE (W. HOSE GUIDE) MVH-R60	1	OX	!4631	*5 EX13
1	4631-17123	BASE/MVH-R60 (N3555-)	1	00	SX	EX13 N3555-
2	9122-12006	ENGINE AY GX120K1SM11NH1	1			GX120/JPN
2	9122-12004	ENGINE AY GX120K1SM12NH1	1		!9122	GX120/MQ
2	9122-12005	ENGINE AY GX120K1SM14NH1	1		!9122	GX EXP/IMER
2	9122-12009	ENGINE AY/GX120U1SM12	1			GX EXP/IMER
2	9112-21303	ENGINE AY EX13 JPN/BLACK	1	AD		EX13/JPN (BL)
2	9112-21304	ENGINE AY EX13 EXP/BL/MM	1	AD		EX13/EXP (BL)
3	0012-20840	BOLT 8X40 T	4			
4	0302-08200	SW M8	4			
5	0311-08160	PW M8	4			
6	4633-42160	BELT COVER PLATE/MVH-R60	1			
7	0012-20820	BOLT 8X20 T	4			
8	0302-08200	SW M8	4			
11	4634-55900	SPACER 18X25.4X13	1			
12	4604-46780	CLUTCH AY A1 /65W	1			
12 -1	9439-20080	CLUTCH, SHAFT, A, Y/MVR-65W	1			
12 -2	9410-10400	CRUTCH PULLY A1124-S18D	1			
12 -6	0802-00300	STOP RING S-30	1			
12 -7	0806-00550	STOP RING AR-55	1			
12 -8	0460-06006	BEARING 6006DDU	1			
13	032-00501-50	KEY	1			
14	4604-46640	WASHER, CLUTCH /MVR-65W	1			
15	0015-20825	SOCKET HEAD BOLT 8X25 T	1			
16	0701-00322	V-BELT RPF-3320	1			
17	4632-16120	DUST COVER /MVH-R60	1		SX	
18	0920-06010	FLAT HEAD SCREW 6X10	4			
19	4633-42030	SPONGE, DUST COVER/MVH-R60	1			
20	4631-17140	BELT COVER /MVH-R60	1			
21	0015-20854	SOCKET HEAD BOLT 8X70 T	4		SX	
23	4631-17130	GUARD FRAME, GX120/MVH-R60	1	DC	!4631	
23	4631-17131	GUARD FRAME, GX120/MVH-R60	1	00	!4631	R60
23	4631-17500	GUARD FRAME / SPRINKLIG	1	AD	SX	R60A
24	0012-21030	BOLT 10X30 T	4	DC		#1
24	0012-21230	BOLT 12X30 T	4	XX		*1
25	0302-10250	SW M10	4	DC		#1
25	0302-12300	SW M12	4	XX		*1
26	4633-42010	STAY (L), HANDLE/MVH-R60	1		SX	
27	4633-42020	STAY (R), HANDLE/MVH-R60	1		!!463	#4 -L2376
27	4633-42021	STAY (R), HANDLE/MVH-R60	1	XX		*4 L2377-
28	0012-21030	BOLT 10X30 T	4			
29	0302-10250	SW M10	4			
30	4589-10020	STOPPER & GRIP SET	1		SX/SS	#4 -L2376
30	4589-10030	STOPPER & GRIP SET	1			*4 L2377-
31	4584-50880	SPRING 1.2-10-29 /MVH-120	1			
33	0254-02516	SPRING PIN 2.5X16	1			
35	4584-50830	RUBBER COVER /MVH-120	1			
36	4584-50810	PLATE, RUBBER COVER/MVH120	1		SX	
37	0012-20825	BOLT 8X25 T	2			
38	0311-08160	PW M8	2			
39	0227-10809	NYLON NUT M8	2			
41	15550-ZK8-P90	DRAIN JOINT	2			E/G PARTS
41	255-63901-11	UNION	2			EX13
42	15552-ZB9-000	DRAIN HOSE	1			E/G PARTS
42	255-63801-03	DRAIN HOSE	1			EX13
43	9540-10070	HOSE BAND 11.5D	2			
43	009-17200-00	HOSE CLAMP	2			EX13
44	90601-ZE1-000	WASHER, DRAIN PLUG	3			E/G PARTS

MVH-R60/R60A/R60L
BODY

4LK0

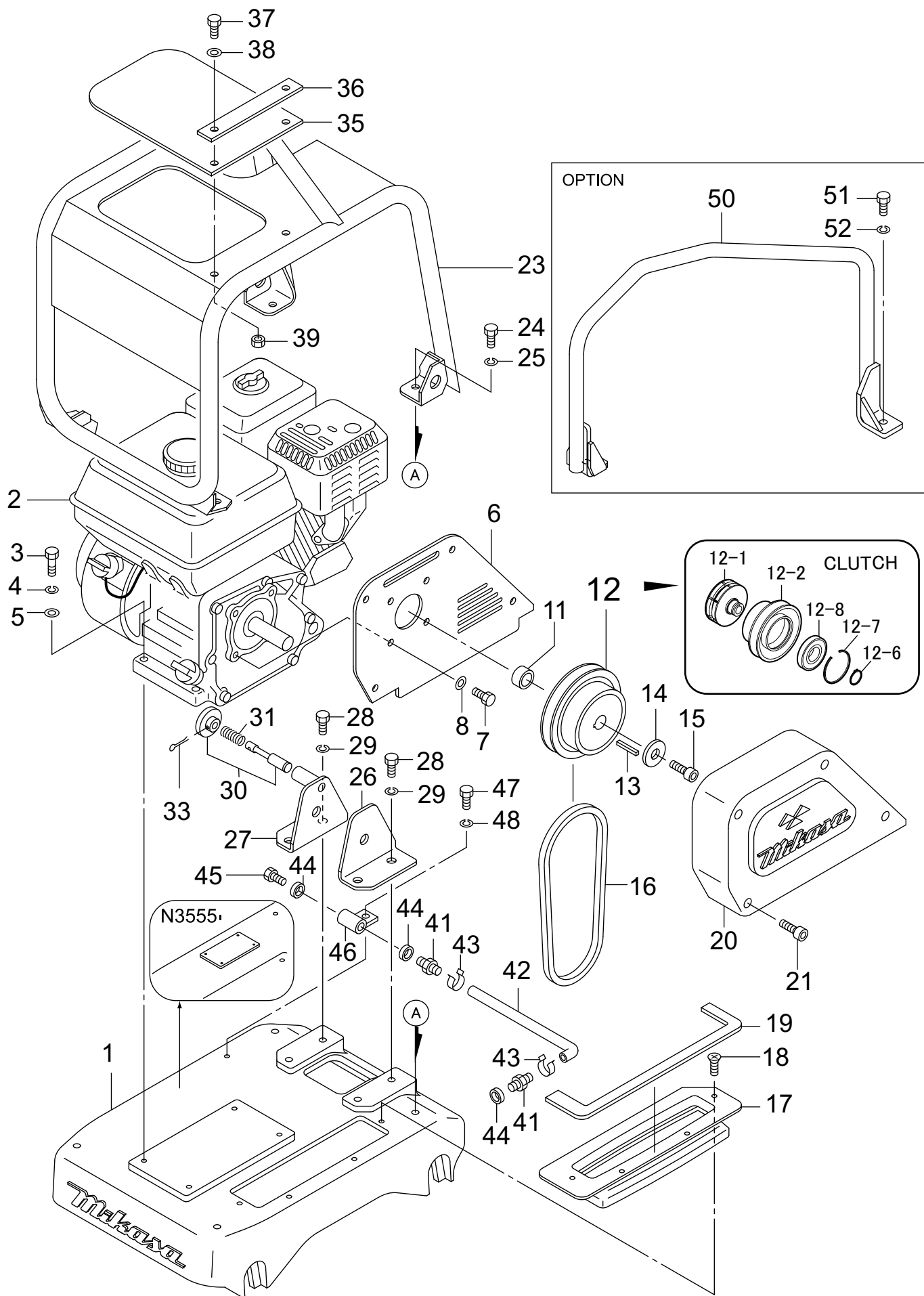

MVH-R60/R60A/R60L
VIBRATOR

4LL

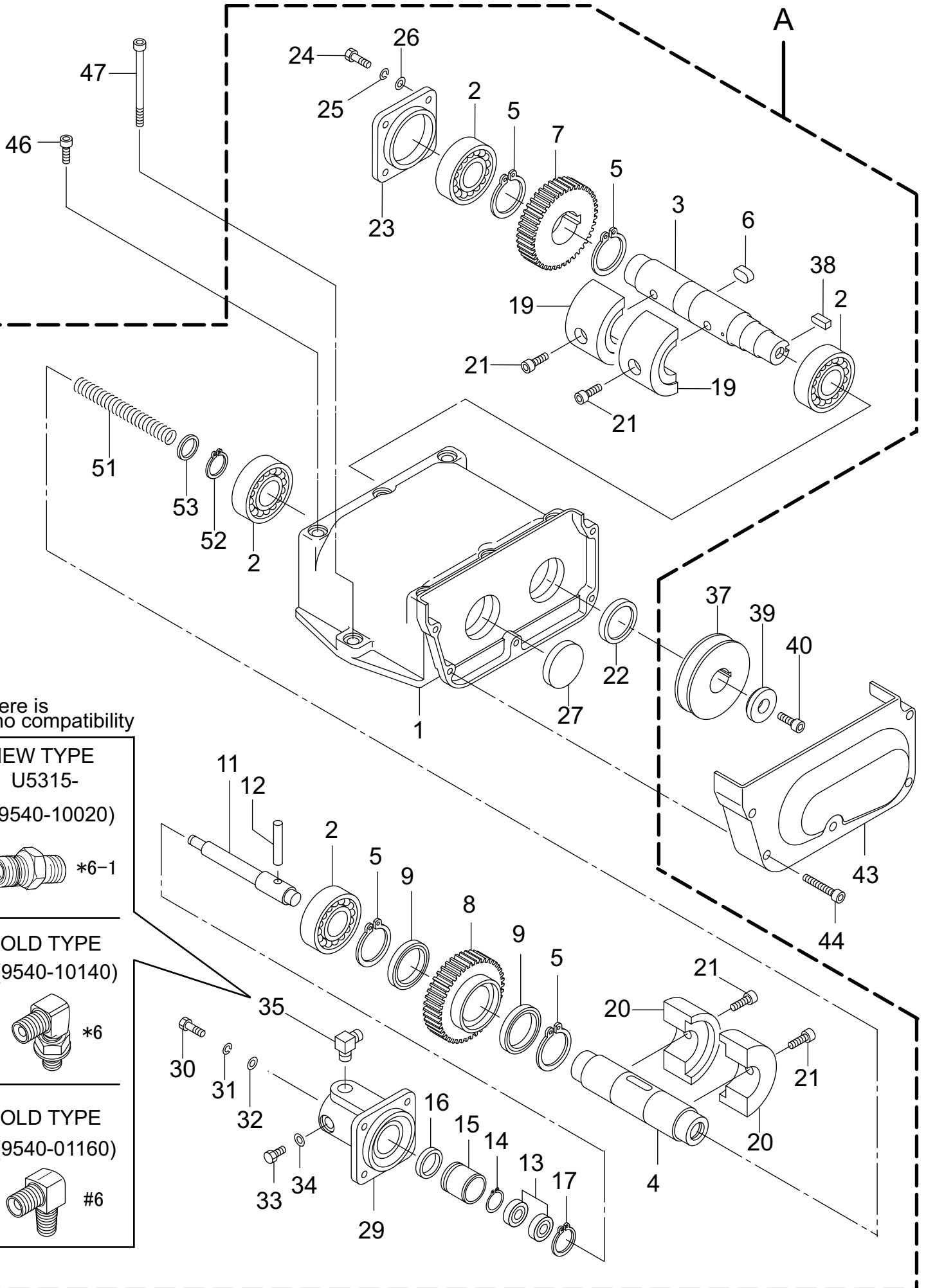

*There is no compatibility

NEW TYPE
U5315-
(9540-10020)



*6-1

OLD TYPE
(9540-10140)

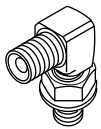

*6

OLD TYPE
(9540-01160)

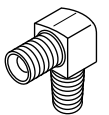

#6

VIBRATOR

** 4LL **

REF NO.	PART NO.	PART NAME	Q' TY	MRK	MK2	REMARKS
A	4639-10030	VIBRATOR, AY/MVH-R60	1			
1	4631-17150	VIBRATING CASE /MVH-R60	1		SX	
2	0404-06206	BEARING 6206C4	4			
3	4633-42040	ROTARY SHAFT, DRIVE/R60	1			
4	4633-42050	ROTARY SHAFT, DRIVEN/R60	1			
5	0802-00350	STOP RING S-35	4			
6	9514-05460	KEY 10X8X19 RR	1			
7	4633-42060	GEAR (DRIVE) /MVH-R60	1			
8	4633-42070	GEAR (DRIVEN) /MVH-R60	1			
9	0403-06807	BEARING 6807C3	2			
11	4633-42080	PISTON ROD /MVH-R60	1			
12	0255-08045	PIN 8X45	1			
13	0425-06000	BEARING 6000ZZSG	2			
14	0802-00100	STOP RING S-10	1			
15	4554-35051	PISTON, 22.4D /MVH-200	1			
16	4550-10070	PACKING USH-22.4X30X5	1			
17	0801-00260	STOP RING R-26	1			
19	4634-55910	ECCENT. ROTATOR, DRIVE/R60	2			
20	4634-55920	ECCENT. ROTATOR, DRIVEN/R60	2			
21	0091-20304	SOCKET HEAD BOLT 10X25 T	4			
22	0602-02040	OIL SEAL SC-28458	1			
23	4634-55930	BEARING COVER /MVH-R60	1			
24	0012-20820	BOLT 8X20 T	4			
25	0302-08200	SW M8	4			
26	0311-08160	PW M8	4			
27	9534-05580	SEAL CAP SC-458 /MVR-65W	1			
29	4633-42090	CYLINDER (PT1/4) R60OLD	1			!R000 #6 -K2159
29	4633-42091	CYLINDER (PF 1/4) /MVH-R60	1	XX		!R003 *6 EX K2160-
29	4633-49940	CYLINDER SLIPPAGE TYPE	1	XX		*6-1 U5307-
30	0012-20820	BOLT 8X20 T	4			
31	0302-08200	SW M8	4			
32	0311-08160	PW M8	4			
33	0012-20812	BOLT 8X12 T	1		SX	
34	9534-04600	COPPER PACKING 8X16X2	1		SX	
35	9540-01160	ELBOW 90° PT1/4-PF1/4	1			#6
35	9540-10140	ELBOW 90° UES90G02G02	1	XX		*6 EX13
35	9540-10020	CONNECTOR PT, PF1/4	1	XX		*6-1 U5307-
37	4633-42100	PULLEY 80D-A1 /MVH-R60	1			
38	9514-05240	KEY 7X7X19 R	1			
39	9524-06920	WASHER 9X(24-35)X10.5/R60	1			
40	0015-20815	SOCKET HEAD BOLT 8X15 T	1			
43	4632-16110	BELT COVER (LOWER) /MVH-R60	1			
44	0015-20640	SOCKET HEAD BOLT 6X40 T	5			
46	0015-21030	SOCKET HEAD BOLT 10X30 T	2			
47	0015-21060	SOCKET HEAD BOLT 10X100 T	6			
51	4634-56200	SPRING 1.2X15.6X130	1			
52	0801-00190	STOP RING R-19	1			
53	0311-08160	PW M8	1			
60	9540-01040	CAP PF1/4	1			

MVH-R60/R60A/R60L
VIBRATOR

4LL

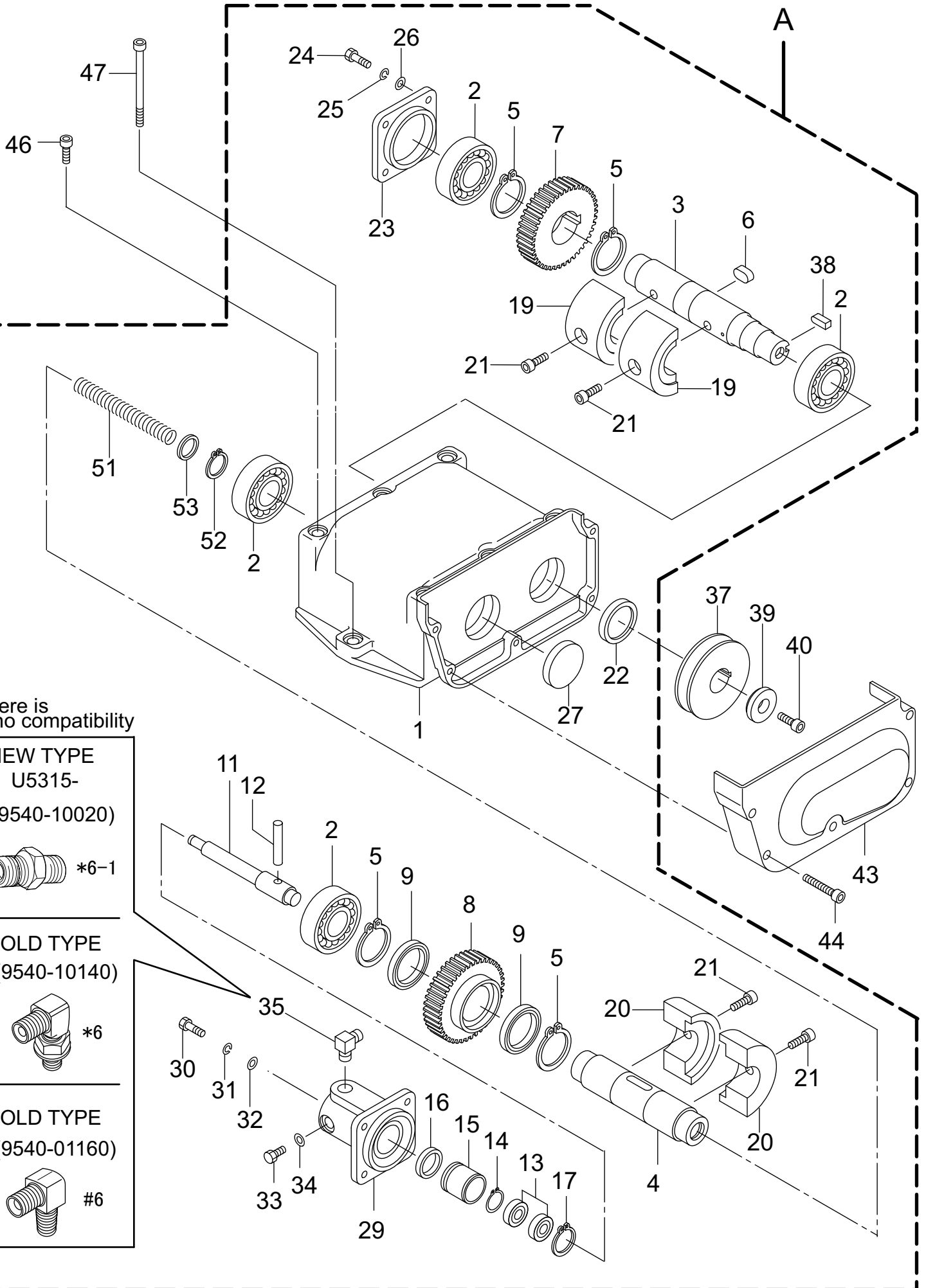

*There is no compatibility

NEW TYPE
U5315-
(9540-10020)



OLD TYPE
(9540-10140)

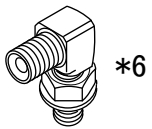

OLD TYPE
(9540-01160)

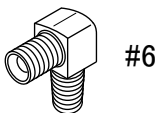

MVH-R60/R60A
CONTROL

2010/12/27

**** 4LM ****

REF NO.	PART NO.	PART NAME	Q' TY	MRK	MK2	REMARKS
1	4633-42110	HANDLE /MVH-R60	1		SX	JP
1	4633-42840	HANDLE /MVH-R60 /MQ, EXP	1			MQ
1	4633-42840	HANDLE /MVH-R60 /MQ, EXP	1			EXP, S4816-
2	4633-42120	BRACKET, HANDLE /MVH-R60	1			JP, -S4900
2	4633-42860	BRACKET, HANDLE/R60/MQ, EXP	1		!R000	MQ, -S4900
2	4633-42860	BRACKET, HANDLE/R60/MQ, EXP	1		!R000	EXP, -S4900
2	4633-48770	BRACKET HANDLE/R60A/JP	1			JP, S4901-
2	4633-48780	BRACKET HANDLE/R60A/EXP	1			MQ, S4901-
2	4633-48780	BRACKET HANDLE/R60A/EXP	1			EXP, S4901-
3	0091-20408	SUNK HEAD BOLT 8X20 T	5			-S4900
3	0091-20408	SUNK HEAD BOLT 8X20 T	1			S4901-
4	0302-08200	SW M8	5	DC		#2
5	0311-08160	PW M8	5	DC		#2
6	0203-08060	NUT M8	5	DC		#2
6	0226-10808	FLANGE NUT M8 H	5	OX		*2, -S4900
6	0226-10808	FLANGE NUT M8 H	1			S4901-
8	0012-21464	BOLT 14X120 T	1		SX	
9	0311-14260	PW M14	2			
10	4584-50660	WASHER 16.4-35-0.6/MVH120	2			
11	0321-14250	CONICAL SPRING WASHER M14	2			
12	0203-14110	NUT M14	2			
13	9390-10220	SHOCK ABSORBER, STOPPER	1			
14	0229-10220	WING NUT M12	1			
16	4633-42190	HAND PUMP AY /MVH-R60	1			
17	4633-42130	TRAVEL LEVER /MVH-R60	1			
18	0015-20820	SOCKET HEAD BOLT 8X20 T	2			
19	4584-51420	COLLAR /MVH-120	1		SX	
20	0339-10030	WAVE WASHER 15.5X20X0.3	4			
21	0012-20854	BOLT 8X70 T	2			
22	0221-30806	CAP NUT M8	2			
23	0302-08200	SW M8	2			
24	0311-08160	PW M8	2			
25	4633-42140	HANDLE GRIP, JAPAN/MVH-R60	1			FOR JAPAN
25	4633-42150	HANDLE GRIP (EXP)/MVH-R60	1			FOR EXPORT
26	9540-02620	OIL HOSE 730L /MVH-R60	1			#3 -K1650
26	9540-02240	OIL HOSE 740L /MVH-R60	1	OX	SX	*5
26	9540-02621	OIL HOSE 780L /MVH-R60	1	XX	SS!95	*3 MQ, LH
26	9540-02250	OIL HOSE 790L /MVH-R60	1	OX		*5 MQ, LH
27	9544-04230	CLAMP SA120-18	1			
28	0012-20620	BOLT 6X20 T	1			
29	0203-06050	NUT M6	1			
30	0302-06150	SW M6	1	DC		#3 -1650
31	0311-06100	PW M6	1			
32	4634-55940	BREATHER CAP /MVH-R60	1			
34	4634-55960	THROTTLE NUT /MVH-R60	1			
35	0015-20510	SOCKET HEAD BOLT 5X10 T	1			
36	4634-55950	SPACER, THROTTLE /MVH-R60	1			
37	3623-41550	THROTTLE BODY /MT-55	1			
38	3629-10090	THROTTLE, GEAR CP, W/BOLT	1			
39	3624-55630	THROTTLE LEVER /MT-55	1			
40	3624-55620	SLIDER /MT-55	1			
41	0501-00450	O-RING G-45	1			
42	0502-00100	O-RING P-10	1			
43	0311-10160	PW M10	3			
44	0321-10180	CONICAL SPRING WASHER M10	2			
45	0962-06006	SOCKET HEAD SCREW 6X6	1			
46	0204-10060	NUT M10, H=6	1			
47	0221-31008	CAP NUT M10	1			
48	0962-08020	SOCKET HEAD SCREW 8X20	1			
49	0204-08050	NUT M8, H=5	1			

MVH-R60/R60A/R60L
CONTROL

4 LM

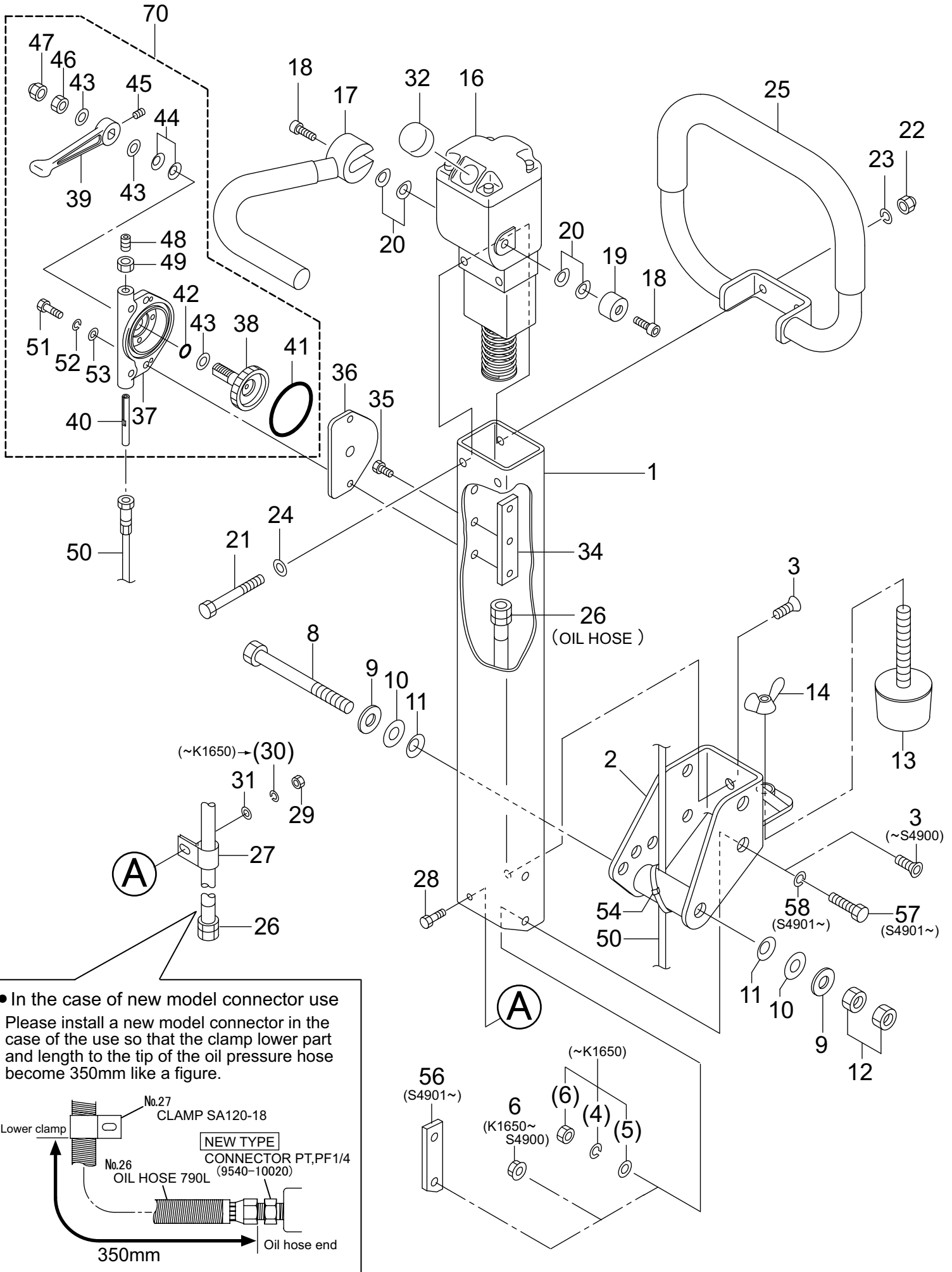

• In the case of new model connector use
Please install a new model connector in the
case of the use so that the clamp lower part
and length to the tip of the oil pressure hose
become 350mm like a figure.

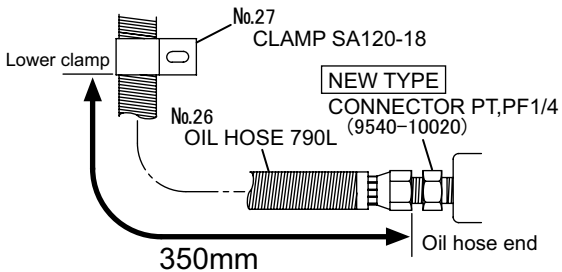

MVH-R60A
 HOOK & SPRINKLING EQUIPMENT

4 L X

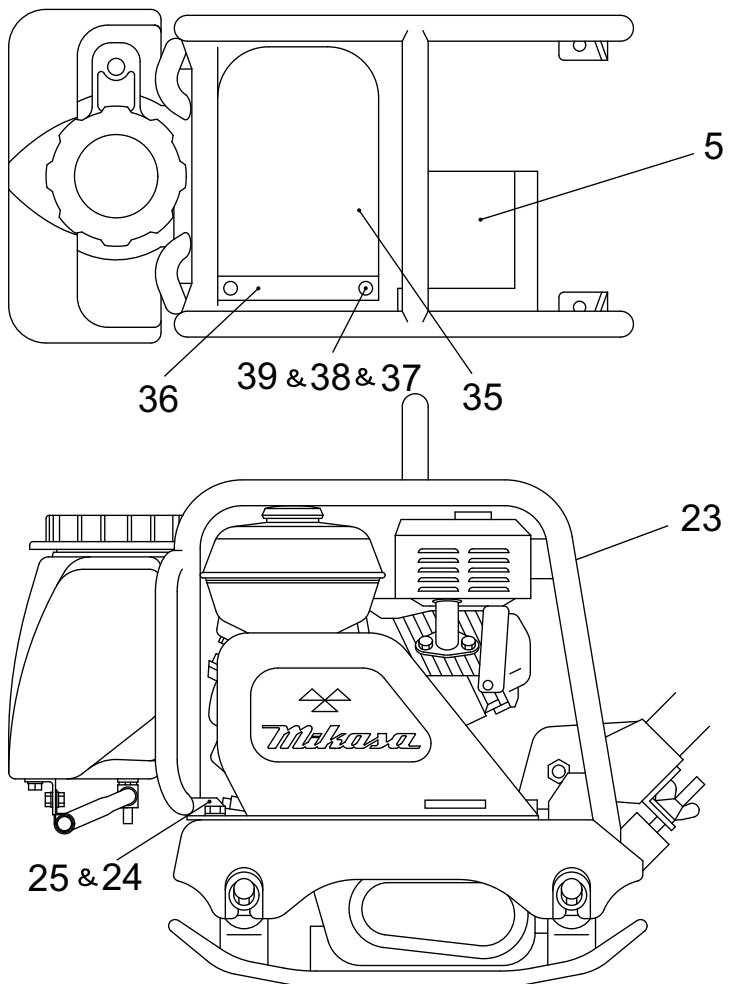
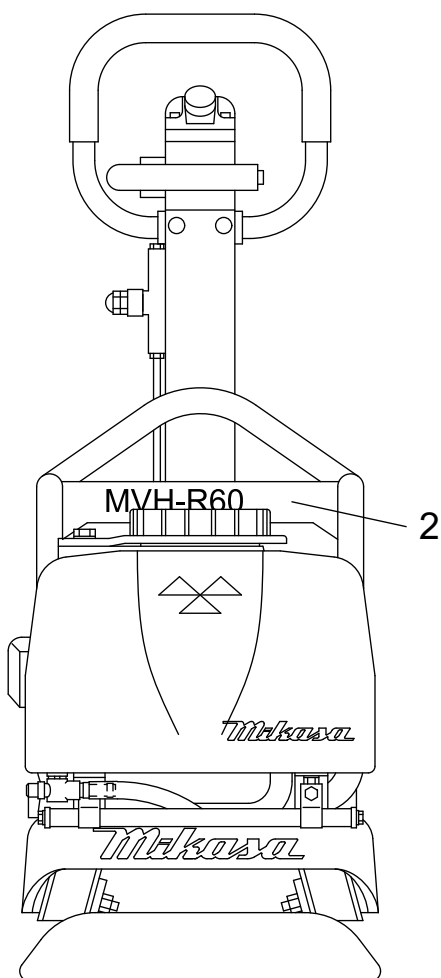
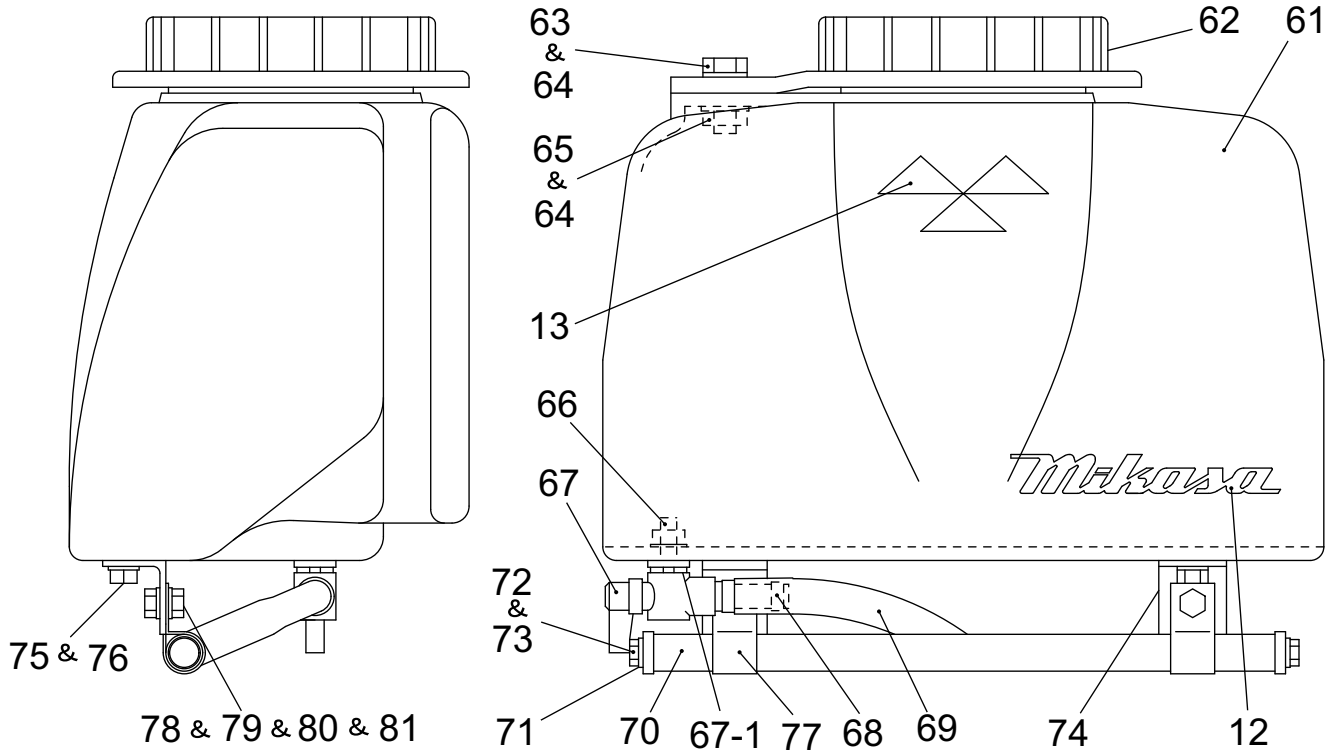

HOOK & SPRINKLING EQUIPMENT

** 4LX **

REF NO.	PART NO.	PART NAME	Q' TY	MRK	MK2	REMARKS
2	9201-10000	DECAL, MODEL MVH-R60	1			
5	9201-09990	DECAL, CAUTION	1			JPN
5	9202-09620	DECAL, CAUTION/R60 ENGLISH	1			EXP
12	9201-09530	DECAL, MIKASA (125MM) YELLOW	1			
13	9201-08850	DECAL, M-MARK Y-40X80	1		SS!92	
23	4631-17500	GUARD FRAME / SPRINKLING	1		SX	
24	0012-21230	BOLT 12X30 T	4			
25	0302-12300	SW M12	4			
35	4584-50830	RUBBER COVER /MVH-120	1			
36	4584-50810	PLATE, RUBBER COVER/MVH120	1		SX	
37	0012-20825	BOLT 8X25 T	2			
38	0311-08160	PW M8	2			
39	0227-10809	NYLON NUT M8	2			
61	4639-10010	WATER TANK W/CAP (BA, R60)	1			INCL. 62-65
62	9543-00342	CAP, WATER TANK (NBR)	1			
63	0012-41030	BOLT 10X30 U	1			
64	0339-10010	WASHER 10.5X21X2 SUS	2			
65	0229-10180	NYLON NUT M10 (SUS)	1			
66	0226-10808	FLANGE NUT M8 H	1			
67	9544-07090	COOK / ANGLE TYPE M8	1			
67 -1	4164-53780	PACKING 8X19X2T	1	AD	!9534	
67 -1	9534-07410	PACKING, 8X15X2T	1			
68	9544-05680	CONNECTOR 1/4X10	1			
69	4634-56580	WATER HOSE / MVH-R60	1			
70	4639-10020	SPRINKLING PIPE A, Y/R60	1			INCL. 71
71	5159-10050	CAP AY, W/BOLT, WASHER /MRH	2			INCL. 72-73
72	0012-20620	BOLT 6X20 T	2			
73	0311-06100	PW M6	2			
74	4634-56570	L TYPE STAY / MVH-R60	2			
75	0012-20815	BOLT 8X15 T	2			
76	0302-08200	SW M8	2			
77	9544-04230	CLAMP SA120-18	2			
78	0012-20615	BOLT 6X15 T	2			
79	0311-06100	PW M6	2			
80	0203-06050	NUT M6	2			
81	0302-06150	SW M6	2			

MVH-R60/R60A/R60L
OPTION (TRANSPORT WHEEL)

4ME

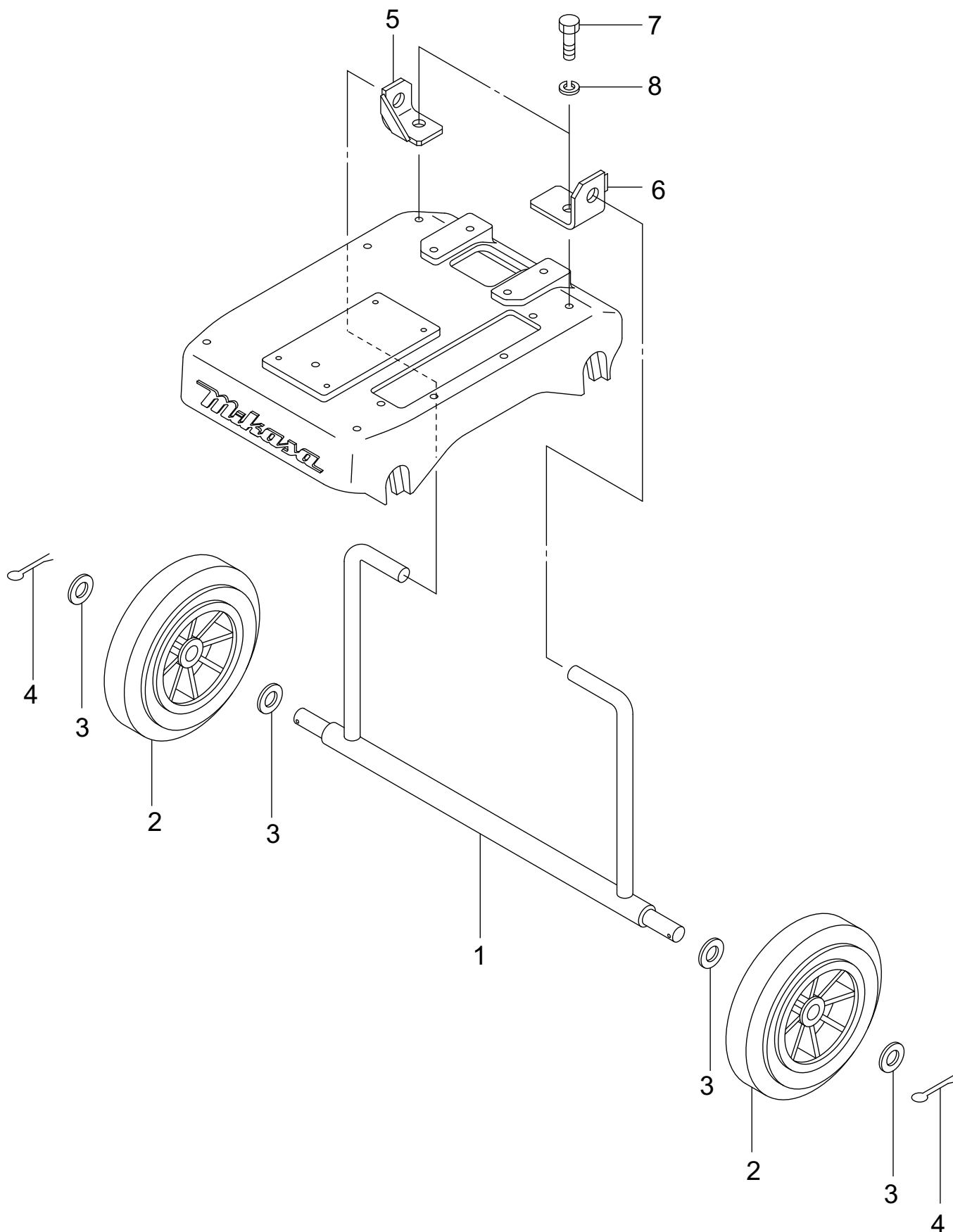

MVH-R60 / R60A / R60L
NAME PLATES

4LO0

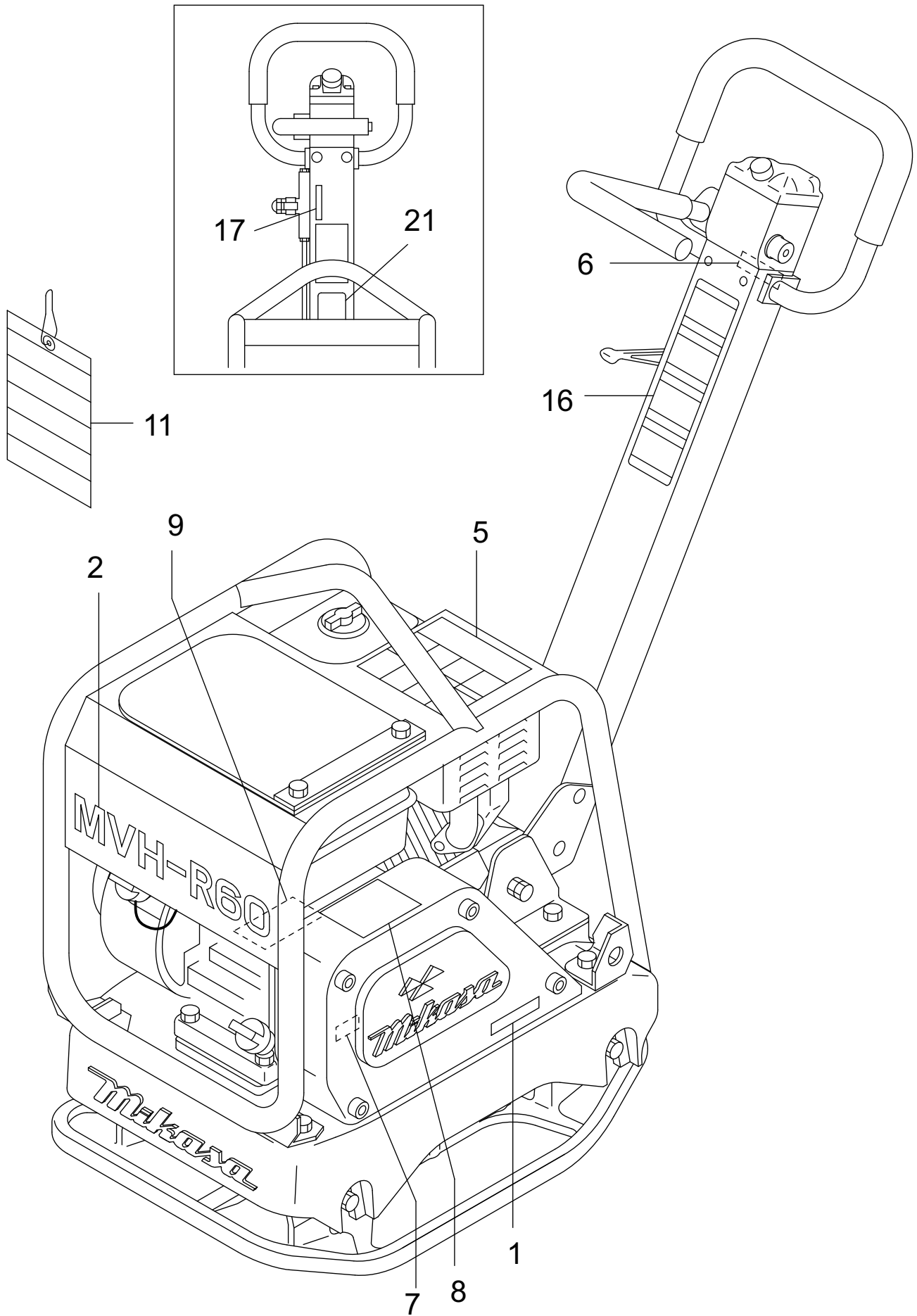



MIKASA SANGYO CO.,LTD.

HEAD OFFICE
NO. 4-3. 1-CHOME, SARUGAKU-CHO, CHIYODA-KU
TOKYO, JAPAN

<http://www.mikosas.com>