

Ü ü ü ü ü ü ü AJ 2015-1A/B panel assembly

Steering panel

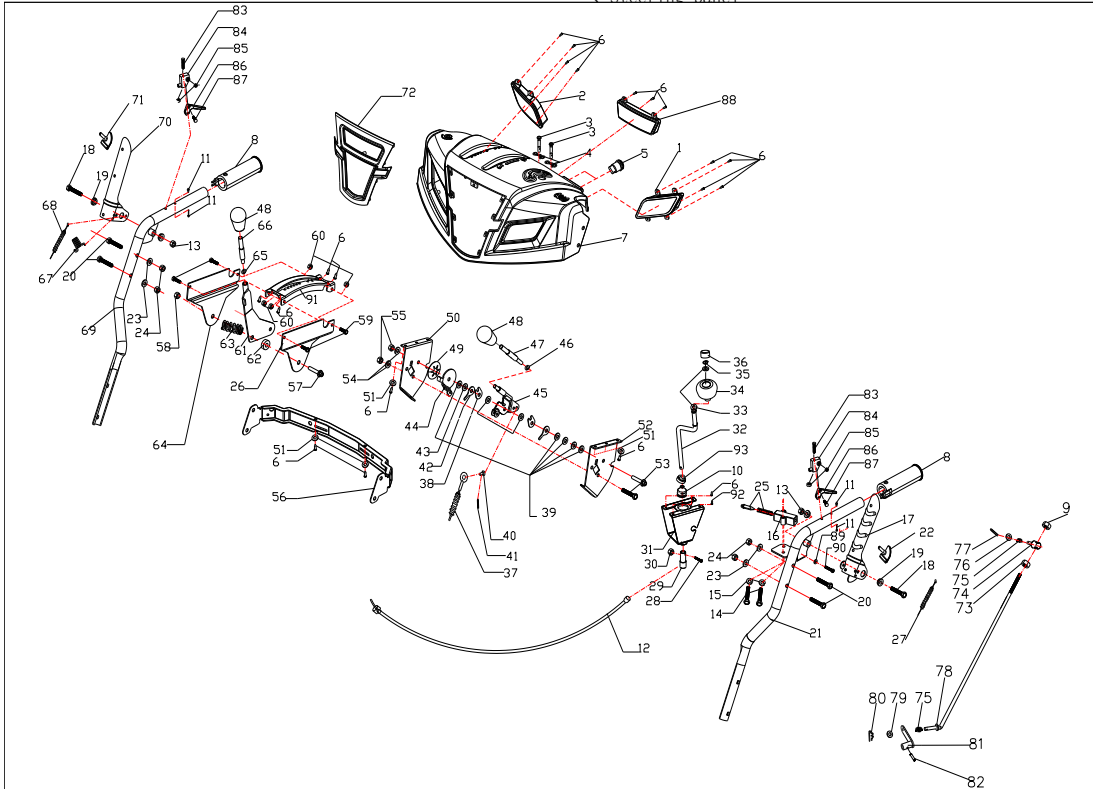

序号	级别	Ü ü ü	编码	English	数量	材料与规格
1	2		13.1.10.01.003	Left head lamp	1	组件 12V
2	2		13.1.10.01.004	Right head lamp	1	组件 12V
3	2	NJ-01	WCM0000S05018	shear pin	2	
4	2	NJ-02	WCY0000S05019	pin buckle	2	
5	2	SA-011-2015	13.1.10.04.002	Switch FT 22	2	12V16A.4针脚
6	2	SH-4.2*16	WBZSH04801200	recessed pan head tapping screw	26	STØ4.2*16
7	2		05.1.10.010	Panel	1	PP
8	2	SX-11-008	ZZSTPRS22037	warm handel sleeve	2	TPR
9	2	NHLN-8	WBZHL00008001	lock nut	1	M8
10	2	ZY-106	XQT000S48003	rubber sleeve 1	1	PU
11	2	BE-4*12	WBZMD00401200	rebite	4	Ø4*12
12	2	2015-011		flexible shaft	1	组件<外购>
13	2	NHLN-8	WBZHL00008001	lock nut	2	M8
14	2	HS-6*18	WBZHS006018001	bolt	2	M6*18
15	2	SW-6	WBZSW00006001	spring gasket	2	Ø6
16	2	2012-KEY-04	WFJ0000S26109	Self-locking mounting	1	粉末冶金
17	2	2011-SX-11-031-4	ZWX000S26053	left handle welding	1	A3
18	2	HS-8*55	WBZHS008055001	bolt	2	M8*55
19	2	SJ-046-1	WFJ0000S05074	Small tensioning pad	4	粉末冶金
20	2	HFB-8*40	WBZHF008040001	flange bolt	4	M8*45
21	2	NF-002-L-B	ZPS000S26056	handel upper tube weld	1	
	3	NF-002A(L)	ZJGS00026057WS	handel upper tube	1	
	3	2011-KEY-01	ZHJ000S26058WS	interlock plate welding assembly	1	
	3	2011-KEY-01-02	ZJG000S26059WS	left clutch fixed plate	1	
	3	2011-KEY-01-03	ZJG000S26060WS	Clutch mounting	1	
	3	SJ-236	ZJG000S16037WS	wire block	1	
22	2	SJ-047-1	ZZS0PUS05086	SJ rubber cap	2	PU
23	2	FB-8*16*1.2	WBZPD08161290	gasket	4	Ø8*Ø16*1.2
24	2	NHLN-8	WBZHL00008001	lock nut	4	M8
25	2	11-SX-11-36K	LKZ1450643001	interlock cable	1	
26	2	NF-001-4-01	WCY00000S26069	Gear rack (left)	1	A3

27	2	SX-11-036B-2	LKZ2051395001	Auger cable	1	
28	2	HS-4*20	WBZHS004020001	bolt	1	M4*20
29	2	2015-004		flexible shaft sleeve	1	45
30	2	NHLN-4	WBZHL000004001	lock nut	1	M4
31	2	2015-01		Rocker block assembly	1	
	3	2015-01-001		Rocker block	1	Q235冷压板
	3	2015-01-002		Rocker block 3	1	Q335冷压板
	3	2015-01-003		flexible shaft 2	1	A3
32	2	ZY-051	WCM00009S4802	Rocker	1	Q235
33	2	FB-10*20*1	WBZPD10201090	gasket	2	Ø10*Ø20*1
34	2	SL-8-11	ZZS0PPS38087	arge chute steering adjust han	1	PP
35	2		WBZZK00001000	external plier	1	0 (GB/T984、2-1986
36	2	SL-8-03	ZZS0PUS38086	arge chute steering handle ba	1	PU
37	2	SX-11-36E	LKZ1781460001	discharge chute wire	1	
38	2	SJ-215	ZWX000S16021	U shape fiche	2	
39	2	FB-8*22*2	WBZPD082220001	gasket	5	Ø8*22*2
40	2	SJ-233	WCM00000S16047	wire pin	1	A3
41	2	OSP-2.0*29	WBZKX02002900	Cotter pin 2	1	2.0*29
42	2	SJ-224	WCY00000S16022	Calabash card	2	
43	2	SA-008	WCY00000S16094	Curved elastic gasket	3	8
44	2	SJ-210-1	WCY00000S16040	the damping mounting p	1	45
45	2	SJ-209	WHJ00000S16017	Adjust rod welding assembly	1	A3
	3	SJ-209-1	WCY00000S16018	Adjust rod welding 1	1	A3
	3	SJ-209-2	WCY00000S16019	Adjust rod welding 2	1	A3
	3	SJ-209-3	WCM00000S16020	Adjust rod welding rod	1	A3
46	2	SW-8	WBZSW000008001	spring gasket	1	Ø8
47	2	2015-003		handel connecting 2	1	A3
48	2	STG8062Ae-26	ZZSPVCS18032	gear handel	2	PVC
49	2	SJ-223	ZWX000S16025	Bowl shrapnel	1	65Mn
50	2	NF-001-7-01	WCY00000S26075	ischarge chute wire fixed b	1	A3
51	2	FB-5*12*1.2	WBZPD051212001	gasket	8	Ø5*12*1.2
52	2	NF-001-7	WCY00000S26073	scharge chute wire fixed br	1	A3
53	2	HS-8*45	WBZHS008045001	bolt	2	M8*45
54	2	FB-8*16*1.2	WBZPD081612001	gasket	2	Ø8*16*1.2
55	2	NHLN-8	WBZHL000008001	lock nut	2	M8
56	2	NF-001-5	ZPS000S26081	Underside coaming	1	A3
57	2	HS-10*45	WBZHS010045001	bolt	1	M10*45
58	2	NHLN-10	WBZHL000010001	lock nut	1	M10
59	2	HS-6*12	WBZHS006012001	bolt	4	M6*12
60	2	NHLN-6	WBZHL000006001	lock nut	4	M6
61	2	NF-001-8	ZWX000S26077	gear plate welding set	1	Q235
	3	NF-001-8-1	WCY00000S26078	gear plate	1	Q235 184*92.5*15
	3	NF-001-8-2	WCM00000S26079	gear handel	1	Q235 M8*Ø16*28
62	2	FB-10*28*3	WBZPD102830001	gasket	1	Ø10*28*3
63	2	STG11 (13) 70 (10) AE-02-08	WTH00000S26083	handel adjust spring	1	
64	2	NF-001-4-02	WCY00000S26070	gear fixed bracket	1	A3
65	2	SW-8	WBZSW000008001	spring gasket	1	Ø8
66	2	2015-002		handle connecting 1	1	A3
67	2	NF-001-14-3	WTH00000S26082	clutch handle spring 3	1	65Mn
68	2	SJ-231	LKZ3101150001	walking wire	1	
69	2	NF-002-R-B	ZPS000S26061	handrail upper tube wel	1	
	3	NF-002A(R)	ZJG000S26062WS	handrail upper tube	1	
	3	2011-KEY-05	ZHJ000S26063WS	right clutch fixed plate welding comp.	1	
	3	2011-KEY-05-01	ZJG000S26064WS	right clutch fixed plate	1	
	3	2011-KEY-01-03	ZJG000S26060WS	clutch fixed sleeve	1	
	3	SJ-236	ZJG000S16037WS	wire fixed block	1	
70	2	2011-SX-11-031-2	ZWX000S26067	right handel	1	A3
71	2	SJ-047-1	ZZS0PUS05086	SJ rubber cap	1	PU

72	2		05.1.10.011	PPGO plastic plate(2015-1	1	PP
	2		05.1.10.012	PPGO plastic plate(2015-1	1	
73	2		WBZFN000008001	flange nut	1	M8
74	2	GPP6562C-01-07	WCM00000S05130	adjusting handel upper conn	1	Q235
75	2	GPP6562C-01-09	WTH00000S05131	adjustable speed adjusting sprin	2	65Mn
76	2		WBZPD082220001	gasket	1	A3 Ø8*22*2
77	2		WBZKK025035001	cotter pin	1	65Mn 2.5*25
78	2	NF-001-18	WCM00000S26084	gear connecting rod	1	
79	2		WBZPD081612001	gasket	1	A3 Ø8*16*1.2
80	2	NJ-02	WTH00000S05019	pin buckle	1	A3
81	2	STG11(13)70(10)AE-02-02-03	WHJ00000S26023	fork arm	1	Q235
	3	STG11(13)70(10)AE-02-02-03-	WCY00000S26024	fork arm plate	1	
	3	STG11(13)70(10)AE-02-02-03-	WCM00000S26025	fork arm sleeve	1	
82	2		WBZJX006030001	Cotter pin	1	65Mn φ6*30
83	2	HS-5*35	WBZHS005035001	bolt	2	M5*35
84	2	SX-11-029	ZZS0PPS22061	handel seat	2	PP黑色
85	2	NHLN-5	WBZHL000005001	lock nut	4	
86	2	SX-11-028	ZZS0PPS22062	handel	2	PP黑色
87	2	SX-11-027	WCM00000S22063	slotted small plate head	2	
88	2		13.1.10.01.005	Head lamp	1	组件 12V
89	2	SW-5	WBZSW000005001	spring gasket	1	φ6
90	2	HS-6*16	WBZHS005016001	bolt	1	M6*16
91	2	2015-001		hang seat	1	Q235-A
92	2	SH-4.2*12	WBZSH04801200	recessed pan head tapping s	1	
93	2	STG8027BS-035		Rocker damping sleeve	1	

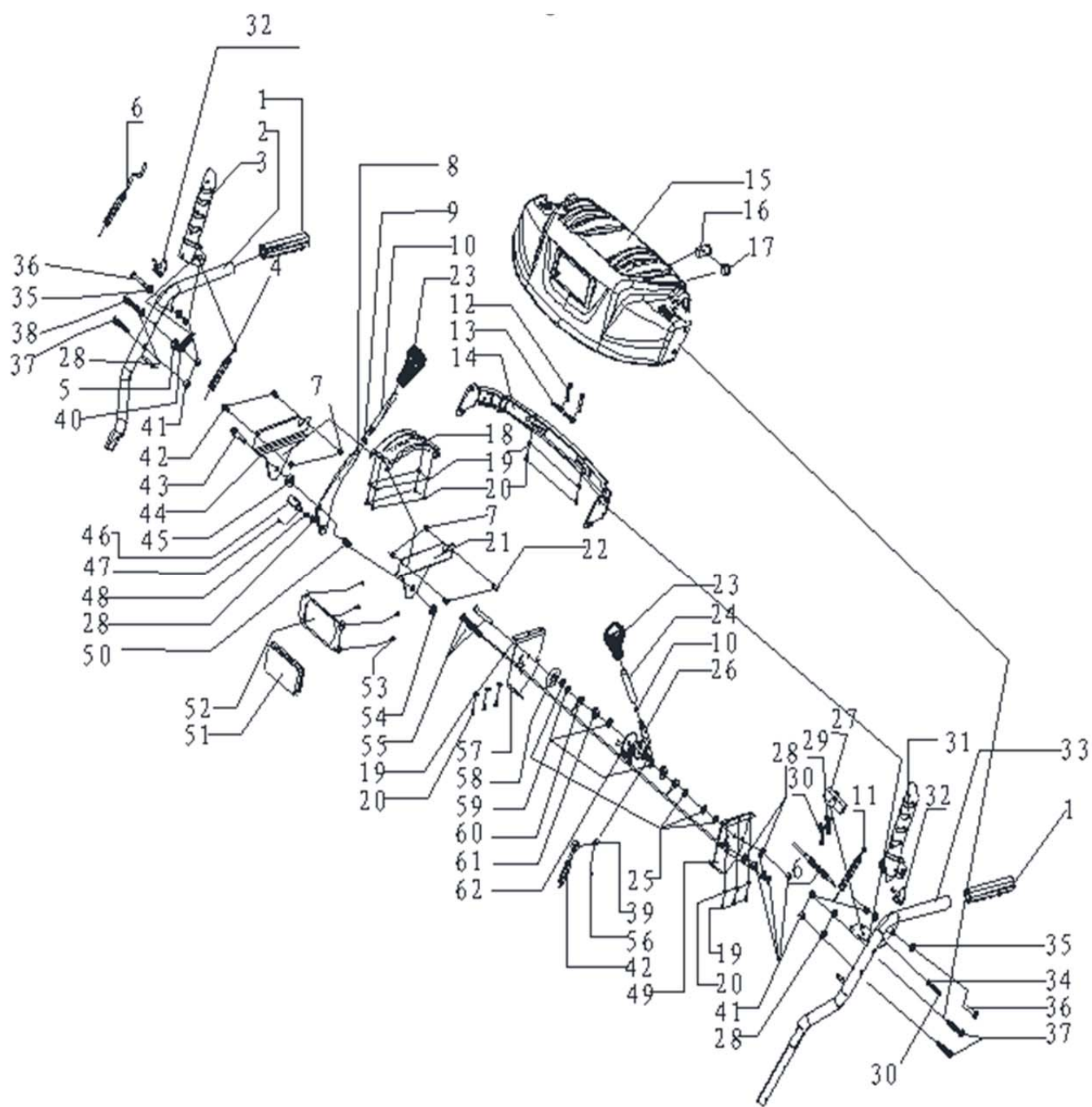

No.	Code No.	English name	Qty
1	STG6556NA-01.10-08	Handle sleeve	2
2	NF-002-R-B	Right handle pipe welding components B-2012	1
3	2012-SX-11-031-2	Right handle welding kit-2012	1
4	SJ-231	Walking cable	1
5	HFN-8	Flange nut	1
6	8-SX-11-36K	Handle self-locking cable-2012	1
7	NHLN-6	Hexagonal self-locking nut	4
8	NF-001-8	Gear plate welding assembly	1
9	SW-8	Spring washer	2
10	NF-001-13-2	Walking gear extension bar	1
11	SX-11-036B-2	Auger cable-2012	1
12	NJ-01	Output shaft bolt	2
13	NJ-02	Pin	2
14	NF-001-5-02	Bottom panel	1
15	NF-010	Plastic panel	1
16	FSMG-25	Handle end cap 25	1
17	SA-011	01 switch	1
18	NF-001-15	Gear plate	1
19	FB-5*12*1	Flat washer	14
20	SHSS-4.8*16	Cross half round head screw	12
21	NF-001-4-01	Gear fixed frame(1)	1
22	HS-6*12	Six angle screw	4
23	STG8062Ae-26	Gear shift handle	2
24	NF-001-13	Chute gear extension bar	1
25	FB-8*22*2	Flat washer	4
26	SJ-209	Adjusting rod welding assembly	1
27	2012-KEY-04	Self locking fixing seat	1
28	FB-8*16*1.2	Flat washer	8
29	SW-6	Spring washer	2
30	HS-6*18	Hexagonal bolt	3
31	SX-11-31-4	Left clutch handle-2012	1
32	SJ-047-1	SJ rubber cap	2
33	NF-002-L	Left handle welding components	1
34	FB-6*12*0.7	Flat washer	1
35	SJ-046-1	Small tension plate pad	4
36	HS-8*55	Hexagonal bolt	2
37	HFB-8*40	Hexagonal bolt	3
38	HS-8*50	Hexagonal bolt	1
39	SJ-233	Cable pin	1
40	NF-001-14-3B	Clutch handle spring	1
41	NHLN-8	Hexagonal self-locking nut	9
42	SX-11-36E	Chute cable	1
43	HS-10*45	Hexagonal bolt	1
44	NF-001-4-02	Gear fixed bracket(2)	1
45	FB-10*28*3	Flat washer	1
46	GPP6562C-01-07	Speed control handle piece	1
47	OSP-2.5*25	Pin 1	1
48	GPP6562C-01-09	Speed control spring 1	1
49	NF-001-7	Left chute gear fixing bracket	1
50	STG11 (13) 70 (10) AE-02-02-08	Handle spring	1
51	L-620	Lamp	1
52	STG8062AE-22	8hp lamp holder	1
53	CHSS-3.2*30	Cross screw	4
54	NHLN-10	Hexagonal self-locking nut	1
55	HS-8*45	Hexagonal bolt	3

56	OSP-2. 0*29	Pin 2	1
57	NF-001-7-01	Right chute gear fixing bracket	1
58	SJ-223	Bowl-shaped gasket	1
59	SA-008	Saddle shaped gasket	3
60	SJ-224	Gourd shaped gasket	2
61	SJ-215	U shape gasket	2
62	SJ-210-1	Adjustable mounting plate 1	1

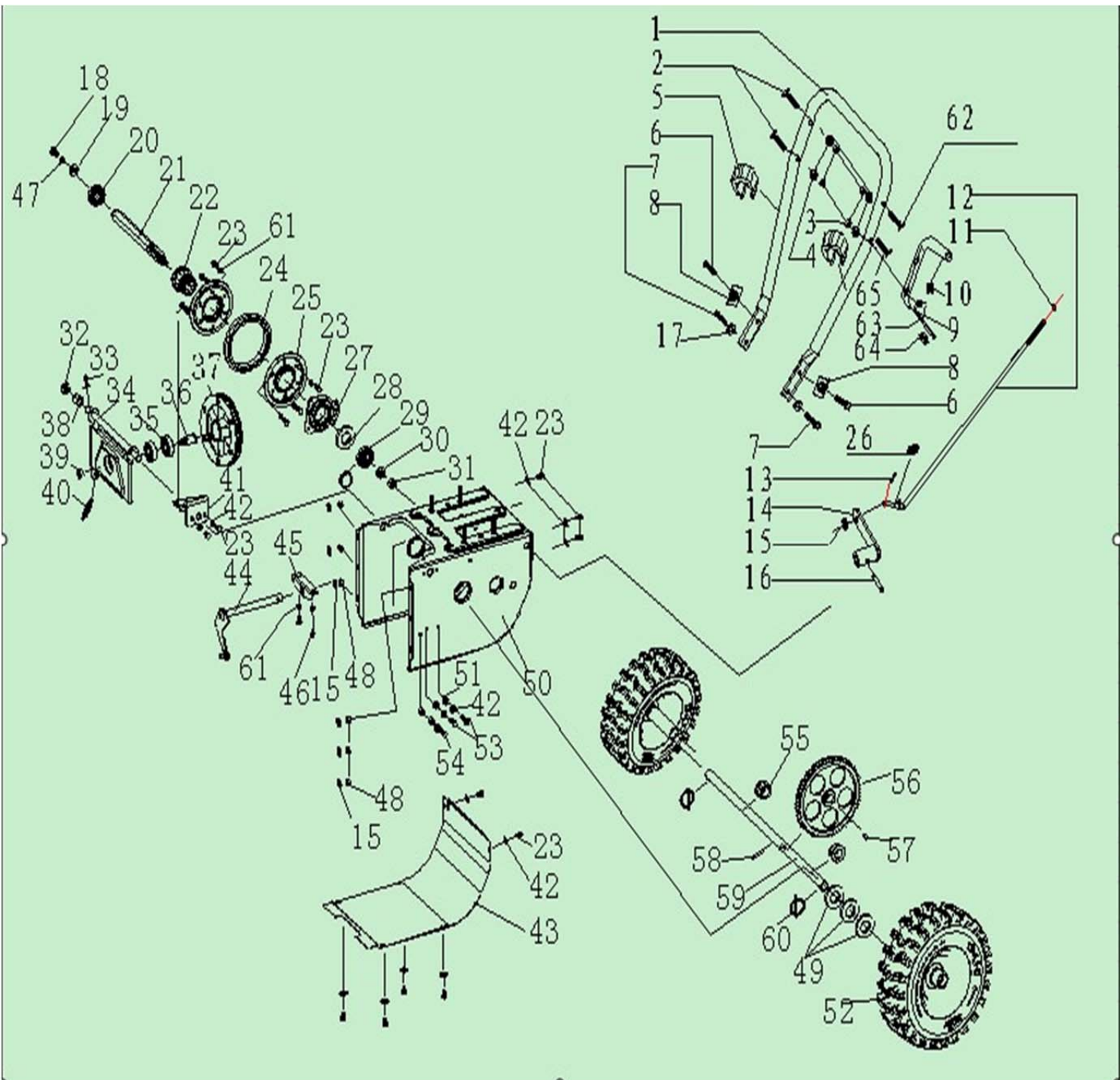

No.	Code No.	English name	Qty
1	SX-11-039	Lower tube of hande bar	1
2	NS-L8*40	Blade bolt	2
3	HFN-8	Flange nut	4
4	BG-8	Blade gasket	4
5	SSG5580A.23-01	28 wire clip	2
6	HFB-8*40	Hexagonal bolt	2
7	HFB-8*20	Hexagonal bolt	2
8	SJ-028	SJ handrail gasket	2
9	NF-20	Chute rocker holder-3-2012	1
10	SJ-239	Helical tooth bracket rocker gasket ring	1
11	HN-8	Hexagonal bolt	1
12	GPP6562C-01-08	Gears-engaging joint lever	1
13	CP-3.2*29	Split pin	1
14	STG11(13)70(10)AE-02-02-03	GPP shifting fork	1
15	FB-8*16*1.2	Gasket	7
16	FRP-6*30	Spring pin	1
17	FB-8*22*2	Washer	2
18	HS-8*16	Hexagonal bolt	1
19	FB-8*28*2	Flat washer	1
20	KBE-6203	Deep groove ball bearing with locking spring	1
21	SJ-005	SJ six angle gear shaft	1
22	SJ-013C	SJ gear wheel	1
23	HS-6*12	Hexagonal bolt	17
24	SJ-013D	SJ rubber ring	1
25	SJ-013A	SJ gear wheel circle	2
26	GPP6562C-01-09	Speed control adjusting spring 1	1
27	SJ-013B	SJ gear wheel cover	2
28	SR-35	Shaft circlip	1
29	KBE-6203	Deep groove ball bearing with locking spring	1
30	FB-10*28*2	Flat washer	1
31	NHLN-10	Hexagonal self-locking nut	1
32	FB-13*24*2	Flat washer	1
33	CP-3*25	Pin	1
34	SJ-007	SJ belt pulley bracket	1套
35	BE-6203	Deep groove ball bearing	2
36	SJ-010B	SJ pulley shaft	1
37	SJ-010A	SJ toothed belt pulley assembly	1
38	SJ-107	SJ sleeve	1
39	NHLN-10	Hexagonal self-locking nut	1
40	SJ-069	Spring 6	1
41	SJ-015	SJ pulley mounting plate 2	1
42	FB-6*12*0.7	Flat washer	14
43	SJ-102	SJ transmission box cover plate	1
44	SJ-040	SJ fork	1套
45	SJ-002	SJ rectangular block	1

46	HS-6*10	Hexagonal bolt	2
47	SW-8	Spring washer	1
48	NHLN-8	Hexagonal self-locking nut	6
49	FB-19*38*1.5	Flat washer	3
50	SJ-103	SJ gearbox shell	1
51	HFN-6	Hexagonal flange bolt	4
52	TC-14	Tyre	2
53	HS-6*30	Hexagonal bolt	2
54	HS-6*20	Hexagonal bolt	1
55	SJ-026	SJ end cap sleeve	2
56	SJ-003	SJ large gear	1
57	WK-5*7.5*19	Semicircle key	2
58	OSP-4*30	Pin	1
59	SJ-017	SJ drive axle	1
60	SJ-066	SJ spring pin	2
61	SW-6	Spring washer	8
62	HFB-8*45	Hexagonal bolt	1
63	SX-11-261	Rocker bracket	1
64	XA-04-100	Chute rocker sleeve	1
65	HFB-8*50	Hexagonal bolt	1

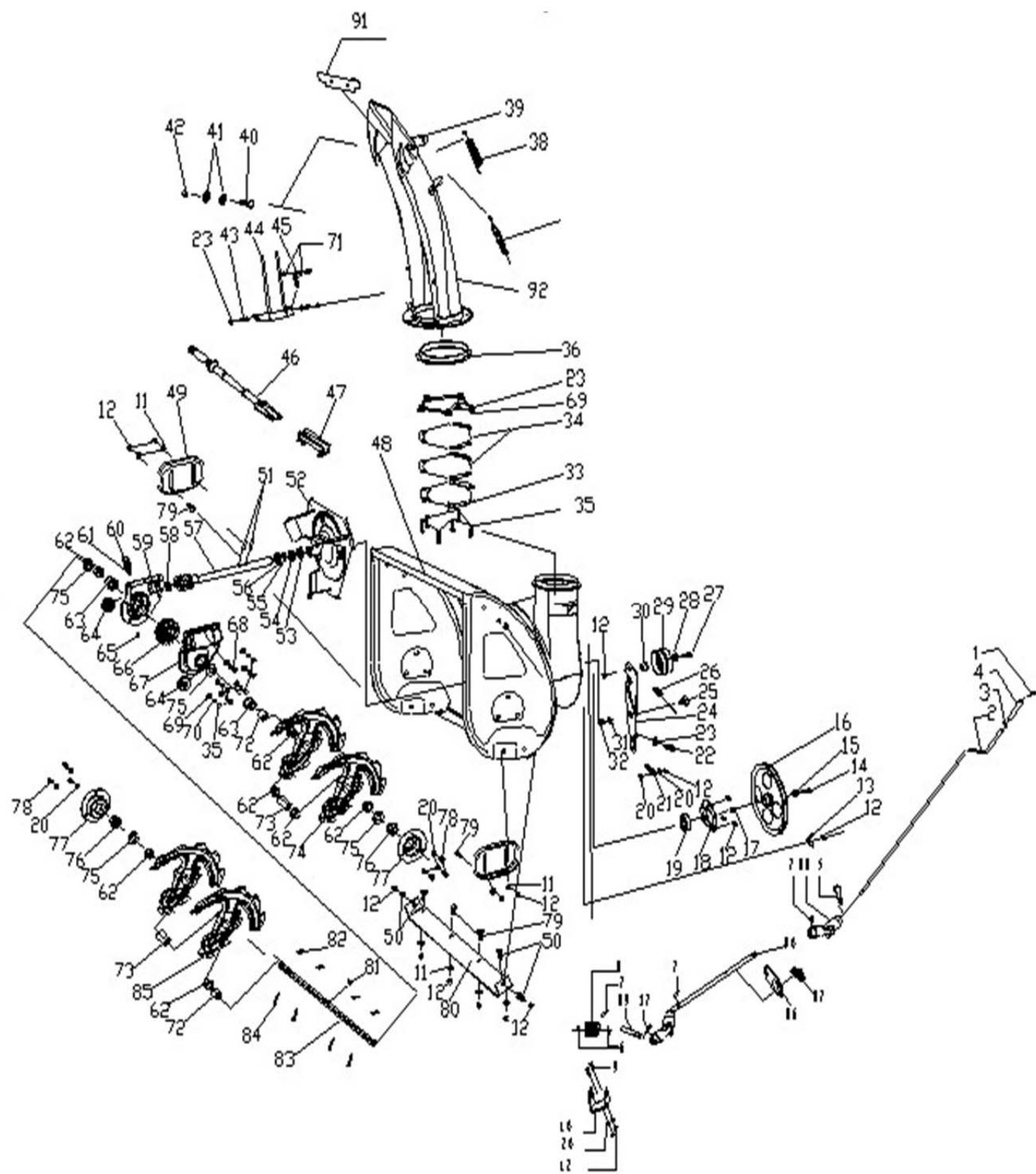

No.	Code No.	English name	Qty
1	HFB-6*16	Hexagonal bolt	M6*16
2	SJ-018	SJ rocker sleeve	胶木
3	FB-10*20*1.5	Flat washer	Φ 10*20*1.5
4	NF-SX-11-075-1	Discharge chute rocker	A3
5	STG11(13)70(10)AE-02-01-020	8 latch pin	65Mn
6	SX-11-259-1	Helical tooth bracket gasket ring	粉末冶金
7	FRP-4*16	Coiled spring pins	Φ4×16
8	SX-11-255-2	Helical gear-2012	45
9	CB-8*18	Half round head screw	2
10	SX-11-259-2	11hp new helical tooth bracket-2012	1
11	FB-8*22*2	Flat washer	8
12	NHLN-8	Hexagonal self-locking nut	15
13	SJ-300	Belt plate	1
14	HS-8*20	Hexagonal flange bolt	1
15	FB-8*28*2	Flat washer	1
16	SJ-039-2	SJ large belt pulley	1
17	FK-C6*17	C type key	1
18	SJ-004	SJ round bottom cover	1
19	BE-UC204	Bearing	1
20	FB-8*16*1.2	Flat washer	8
21	SJ-037	Spring 5	1
22	SJ-023-2	Tension screw	1
23	NHLN-6	Hexagonal self-locking nut	9
24	STG-8062-50	SJ tension plate	A3
25	SJ-050	SJ hexagonal bolt 1	1
26	SJ-230	Auger cable	1
27	HS-8*45	Hexagonal bolt	1
28	SJ-008C	SJ sleeve	1
29	SJ-008	SJ large tension wheel 2 (bearing)	1套
30	SJ-008B	SJ sleeve	1
31	FB-10*20*2	Flat washer	1
32	NHLN-10	Hexagonal self-locking nut	1
33	SJ-021	Chute gasket	3
34	SJ-021C	Chute gasket	6
35	HS-6*20	Hexagonal bolt	12
36	SJ-237	Chute base plastic ring	1
37	CP-3.2*25	Pin	1
38	SJ-226	Chute spring	1
39	SX-11-105-1	Chute cap assembly 2012	1套
40	SHS-5*12	Cross head screws	1
41	SJ-200-8	Chute nylon gasket	2
42	NHLN-5	Hexagonal self-locking nut	1
43	HS-6*16	Hexagonal bolt	3
44	SJ-012	SJ bend rod kit	1套
45	SJ-036	Spring 4	1
46	SJ-150	Plastic shovel	1
47	SJ-151	Shovel seat	1
48	SJ-104-2	SJ box	1
49	SJ-111	SJ skid	2
50	CB-8*20	Half round head screw	4
51	FRP-6*30	Coiled spring pins	2
52	SJ-001	SJ fan	1套
53	OS-32*20*6	Oil seal	1
54	BE-51104	Single direction thrust ball	1

		bearing	
55	SJ-057	Spacer ring	1
56	BE-6904	Deep groove ball bearing	1
57	SJ-030	SJ drive worm gear shaft	1
58	BE-16001	Deep groove ball bearing	1
59	SJ-101A	SJ bottom base	1
60	RM-5HP	Grease nipple	1
61	WG-10	Corrugated gasket	1
62	SJ-019	SJ drive shaft sleeve	2
63	SJ-108-1	SJ output shaft sleeve	2
64	OS-30*19*7	Oil seal	2
65	SHS-5*12	Cross head screws	1
66	SJ-038	SJ worm wheel	1
67	SJ-101	SJ upper base	1
68	SHS-6*25	Hexagonal bolt	1
69	FB-6*12*0.7	Flat washer	13
70	SW-6	Spring washer	7
71	HFN-8	Hexagonal flange bolt	2
72	STG24-2	Output shaft sleeve 24-2	2
73	STG24-1	Output shaft sleeve 24-1	2
74	30-SX-11-125	Right auger	2
75	FB-19*38*1.5	Flat washer	4
76	SJ-020	SJ bushing	2
77	SJ-024	SJ bearing cover	2
78	HS-8*10	Hexagonal bolt	6
79	CB-8*16	Half round head screw	4
80	SJ-006-2	SJ long plate	1
81	WK-5*7.5*19	Semicircle key	1
82	NJ-02	Pin	4
83	24-SX-11-134	Output shaft 24	1
84	NJ-01	Output shaft pin	4
85	30-SX-11-135	Left auger	2
86	SX-11 (13) 70 (10) -02-01-19	Chute rocker fixed frame	1
87	SJ-239	Helical tooth rocker gasket	1
88	SX-11-257	Universal coupling	2
89	2012-SX-11-84-3	Chute helical tooth rocker	Q235
90	2012-STG8062-101	Chute rocker 1	1
91	2012-SX-11-400	Chute rubber gasket	1
92	2012-SX-11-106-12	11hp 12 type chute assembly	1套

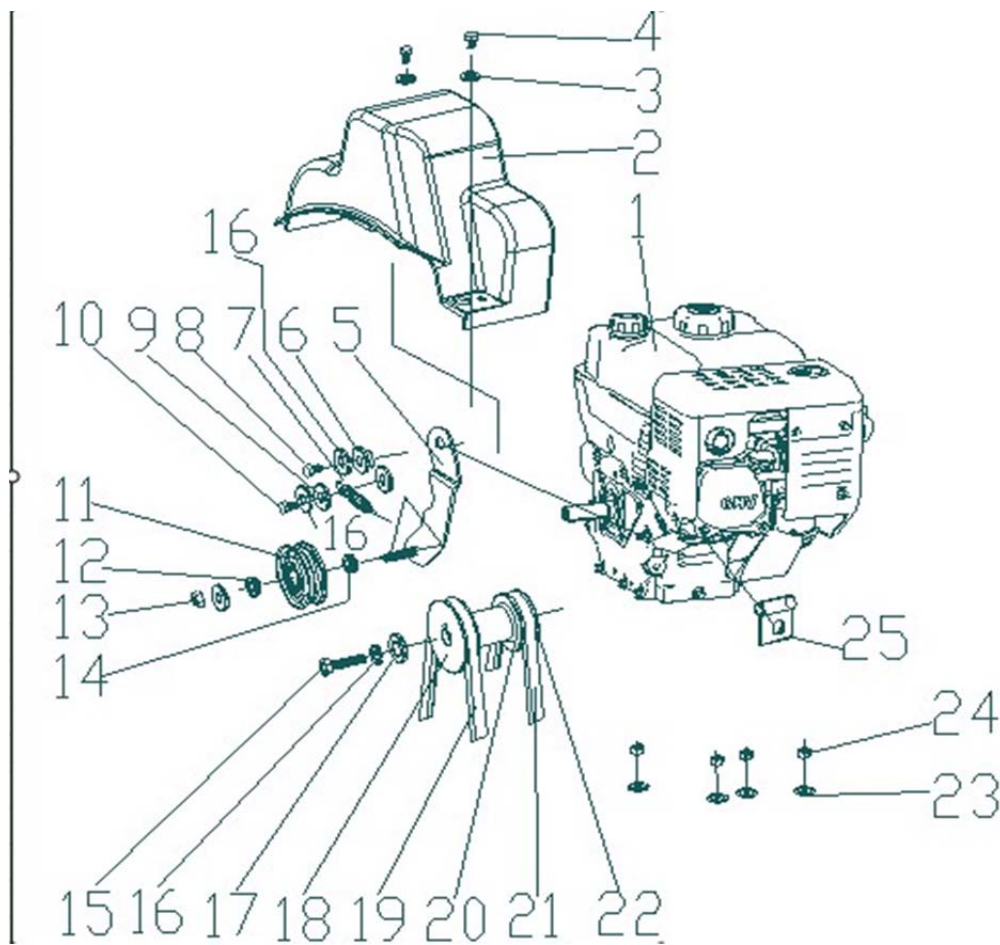

No.	Code No.	English name	Qty
1	LC175	Engine	1
2	SX-11-180	Pulley cover	1
3	FB-6*16*1.5	Flat washer	2
4	HS-6*12	Hexagonal bolt	2
5	SJ-045	SJ small tension plate	1
6	SJ-046-1	Small tension plate washer	1
7	SJ-035-1	SJ spring 3	1
8	HS-8*20	Hexagonal bolt	1
9	FB-8*16*1.2	Flat washer	3
10	HS-8*16	Hexagonal bolt	1
11	SX-11-170	Small tension wheel set (ball bearing)	1套
12	SJ-008C	Sleeve	1
13	NHLN-8	Hexagonal self-locking nut	1
14	SX-11-170B	Small tension plate washer	1
15	HFB-8*25	Hexagonal bolt	1
16	SW-8	Spring washer	3
17	FB-8*28*3	Flat washer	1
18	STG9056Ae-01-01	SJ main pulley	1
19	LB4L-930	V shaped belt	1
20	SX-11-168C	Small pulley washer	1
21	TB-5M*825	Toothed belt	1

22	SX-11-168b	Main toothed belt pulley	1
23	FB-10*20*2	Flat washer	4
24	NHLN-10	Hexagonal self-locking nut	4
25	FD-04-62	Cable fixed lock	1