

	300 TRENDY	PROTEZIONI MOTORE		DALLA MACCHINA DE LA MAQUINA DE LA MACHINA FROM THE MACHINE AB DER MASCHINE	N.	857706	Rev.
		ENGINE PROTECTIONS PROTECCIONES MOTOR	PROTECTIONS MOTEUR MOTORSCHUTZ				C01
						03/2011	

Pos.	Code	Q.ty	Description	Notes
31100451	31100451	1	SCREW 3,5X25	
31112085	31112085	1	SCREW TE M6X16 DIN 6921 8G	
31112154	31112154	1	SCREW TE M8X40 UNI 5739 8G	
31241060	31241060	1	SELFLOCK NUT M6	
31241084	31241084	1	SELFLOCK NUT M8 6S	
31411064	31411064	1	WASHER 6,4x12,5	
31510100	31510100	1	RIBBED SCREW 6,3X19 UNI 6950	
55252405	55252405	1	GUARD	
55252406	55252406	1	GUARD	
55252413	55252413	1	GUARD	
55252503	55252503	1	FREGIO ANT.MC 2010 FERRARI	
55252504	55252504	1	HALF BEARING	
56157393	56157393	1	HOLDER	
56157394	56157394	1	STOP	
56157399	56157399	1	HOLDER	
58048035	58048035	1	HOLDER	
58056991	58056991	1	CABLE GLAND	
58057385	58057385	1	LINE	
59053021	59053021H	1	BUMPER C.15LD-ACT-GX ALUM.	
59053040	59053040H	1	PARAURTI COM.GX160-200 ALLUM.	
59056127	59056127H	1	BUMPER FOR 740	

SERIAL
START
857706

ENGINE PROTECTIONS

CODE REV
C01_3_60548

ROBIN EX 17 - HONDA Gx 120/160/200 31100003
 HONDA Gx 240/270/340/390 31100015
 HONDA Gx 240/270/340/390 31423105
 31423084

31312088
 31312083
 31211080
 31241080 ⚡
 31423084

ROBIN EX 17 - HONDA Gx 120/160/200 53247488
 HONDA Gx 240/270/340/390 53156150

MOTORE ENGINE MOTEUR MOTOR MOTOR	FRIZIONE CLUTCH A EMBRAYAGE EMBRAGUE KUPPLUNG
Acme A220	59247884
Acme A220 (REF.)	59256255
Acme ACT 280 - A349 - A360	59247884
Acme ACT 340	59247971
Honda Gx 390 - Gx 340 D=25,4	59256280
Honda Gx 240/270 D=25,4	59256279
Honda Gx 120/160/200 D=19	59256275
Lombardini 15LD315/350	59247884
Lombardini 15LD440 ★	59247971
Lombardini 15LD500	59247924
ROBIN EX 17 ★	59256275
Yanmar L100AE	59247971
Yanmar L70AE	59247884

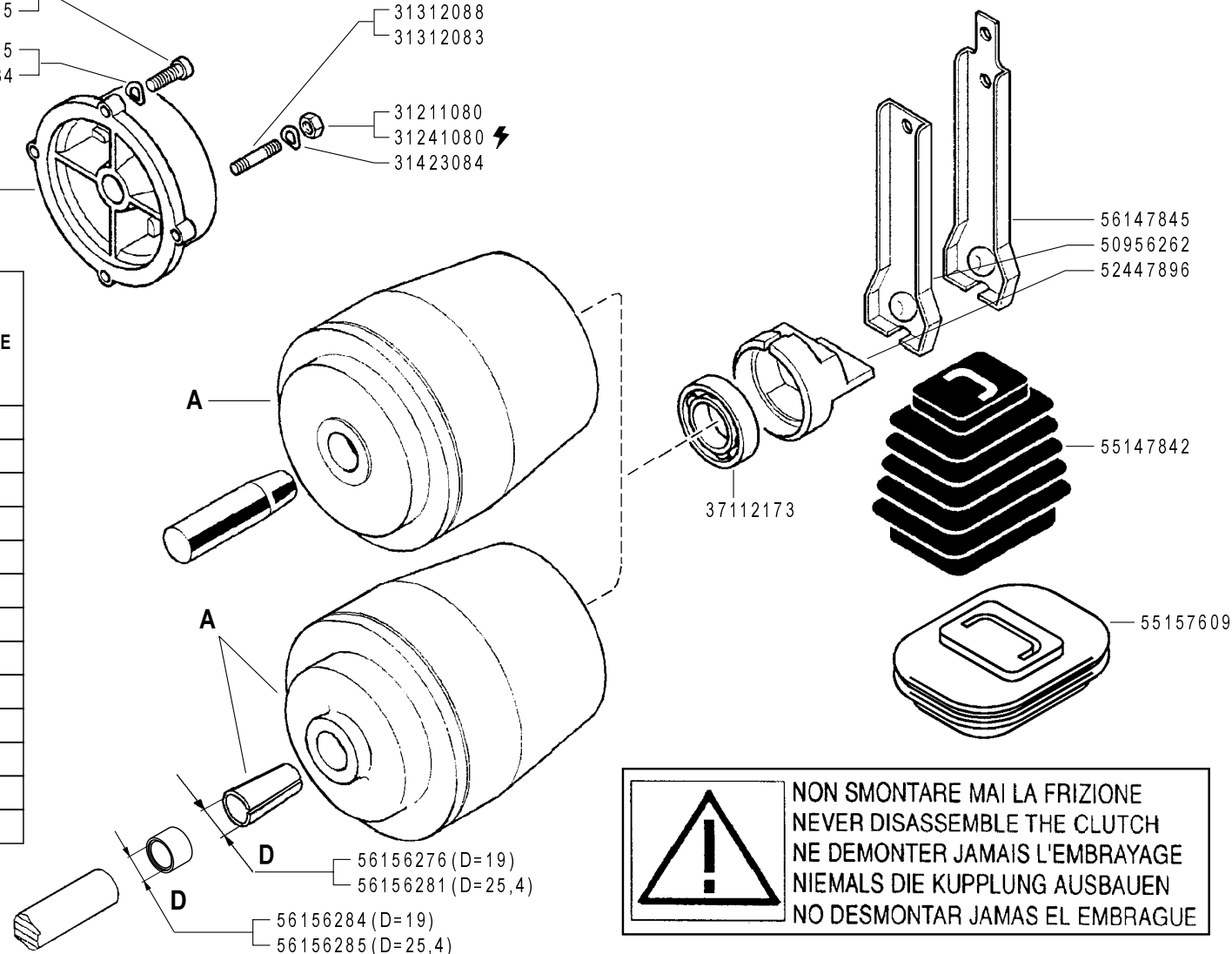

⚠ NON SMONTARE MAI LA FRIZIONE
 NEVER DISASSEMBLE THE CLUTCH
 NE DEMONTER JAMAIS L'EMBRAYAGE
 NIEMALS DIE KUPPLUNG AUSBAUEN
 NO DESMONTAR JAMAS EL EMBRAGUE

FERRARI **300 TRENDY**

FRIZIONE A CONO AUTOVENTILANTE
 CLUTCH
 EMBRAYAGE
 EMBRAGUE
 KUPPLUNG

DALLA MACCHINA
 FROM THE MACHINE
 DE LA MACHINE
 DE LA MAQUINA
 AB DER MASCHINE
 ★ N.

AGGIORNAMENTO
REVISION
MISE A JOUR
APLAZAMIENTO
ANPASSUNG

Rev. **D01** **2**
 10/2008

Pos.	Code	Q.ty	Description	Notes
31100003	31100003	1	SCREW TE 5/16X7/8	
31100015	31100015	1	SCREW TE 3/8X1	
31211080	31211080	1	NUT M8	
31241080	31241080	1	SELFLOCK NUT M8	
31312083	31312083	1	STUD BOLT M8X46X16X16	
31312088	31312088	1	STUD BOLT M8X40X14X14	
31423084	31423084	1	SPRING WASHER 8,4	
31423105	31423105	1	SPRING WASHER 10,5	
37112173	37112173	1	BEARING	
50956262	50956262	1	CLUTCH LEVER	
52447896	52447896	1	PRESSURE PLATE	
53156150	53156150	1	ENGINE FLANGE	
53247488	53247488	1	ENGINE FLANGE	
55147842	55147842	1	BELLOWS	
55157609	55157609	1	BELLOWS	
56147845	56147845	1	CLUTCH LEVER	
56156276	56156276	1	SLEEVE	
56156281	56156281	1	CENTRING BUSH	
56156284	56156284	1	SPACER	
56156285	56156285	1	SPACER	
59247884	59247884	1	CLUTCH ASSY	
59247924	59247924	1	CLUTCH	
59247971	59247971	1	CLUTCH	
59256255	59256255	1	CLUTCH ASSY	
59256275	59256275	1	CLUTCH ASSY	
59256279	59256279	1	CLUTCH ASSY	
59256280	59256280	1	CLUTCH ASSY	

SERIAL

CLUTCH

CODE REV

D01_2_60564

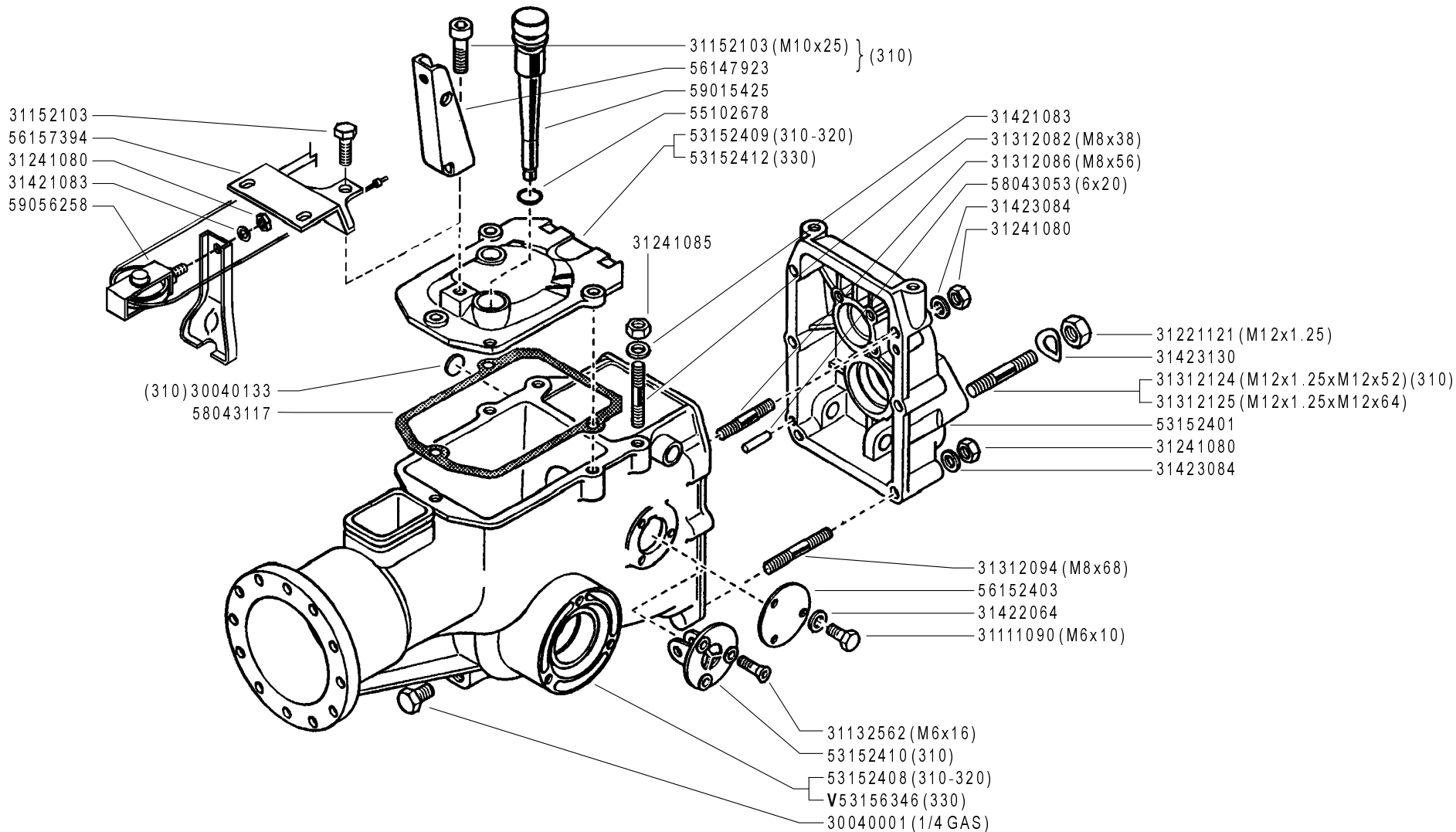

V = verde - green - vert - grün

FERRARI

300 TRENDY

SCATOLA CAMBIO

GEARBOX
CAJA DE CAMBIO

BOITE DE VITESSES
WECHSELGETRIEBE

DALLA MACCHINA
FROM THE MACHINE
DE LA MACHINE
DE LA MAQUINA
AB DER MASCHINE

N.

E01 0

11/2006

Rev.

ZENNE

Pos.	Code	Q.ty	Description	Notes
30040001	30040001	1	PLUG	
30040133	30040133	1	PLUG 22 DIN 470	
31111090	31111090	1	SCREW TE M5X10 UNI 5739 8G	
31132562	31132562	1	SCREW TSVEI M6X16 UNI 5933	
31152103	31152103	1	SCREW TCEI M10X25 UNI 5931	
31221121	31221121	1	NUT M12X1,25	
31241080	31241080	1	SELFLOCK NUT M8	
31241085	31241085	1	SELFLOCK NUT M8 6S	
31312082	31312082	1	STUD BOLT M8X38X14X20	
31312086	31312086	1	STUD BOLT M8X56X20X14	
31312094	31312094	1	STUD BOLT M8X68X14X36	
31312124	31312124	1	STUD BOLT	
31312125	31312125	1	STUD BOLT	
31421083	31421083	1	WASHER	
31422064	31422064	1	SPRING WASHER 6,4	
31423084	31423084	1	SPRING WASHER 8,4	
31423130	31423130	1	SPRING WASHER 13	
53152401	53152401	1	REAR COVER	
53152408	53152408	1	BODY	
53152409	53152409	1	COVER	
53152410	53152410	1	GEAR SUPPORT	
53152412	53152412	1	COPERCHIO SCAT.CAMBIO DIFF.*V*	
53156346	53156346	1	BODY	
55102678	55102678	1	RUBBER RING	
56147923	56147923	1	BRACKET	
56152403	56152403	1	COVER	
56157394	56157394	1	STOP	
58043053	58043053	1	CYLINDRICAL PLUG	
58043117	58043117	1	COVER GASKET	
59015425	59015425	1	PLUG	
59056258	59056258	1	CLUTCH FORK	

SERIAL

GEARBOX

CODE REV

E01_0_27146

GEARS

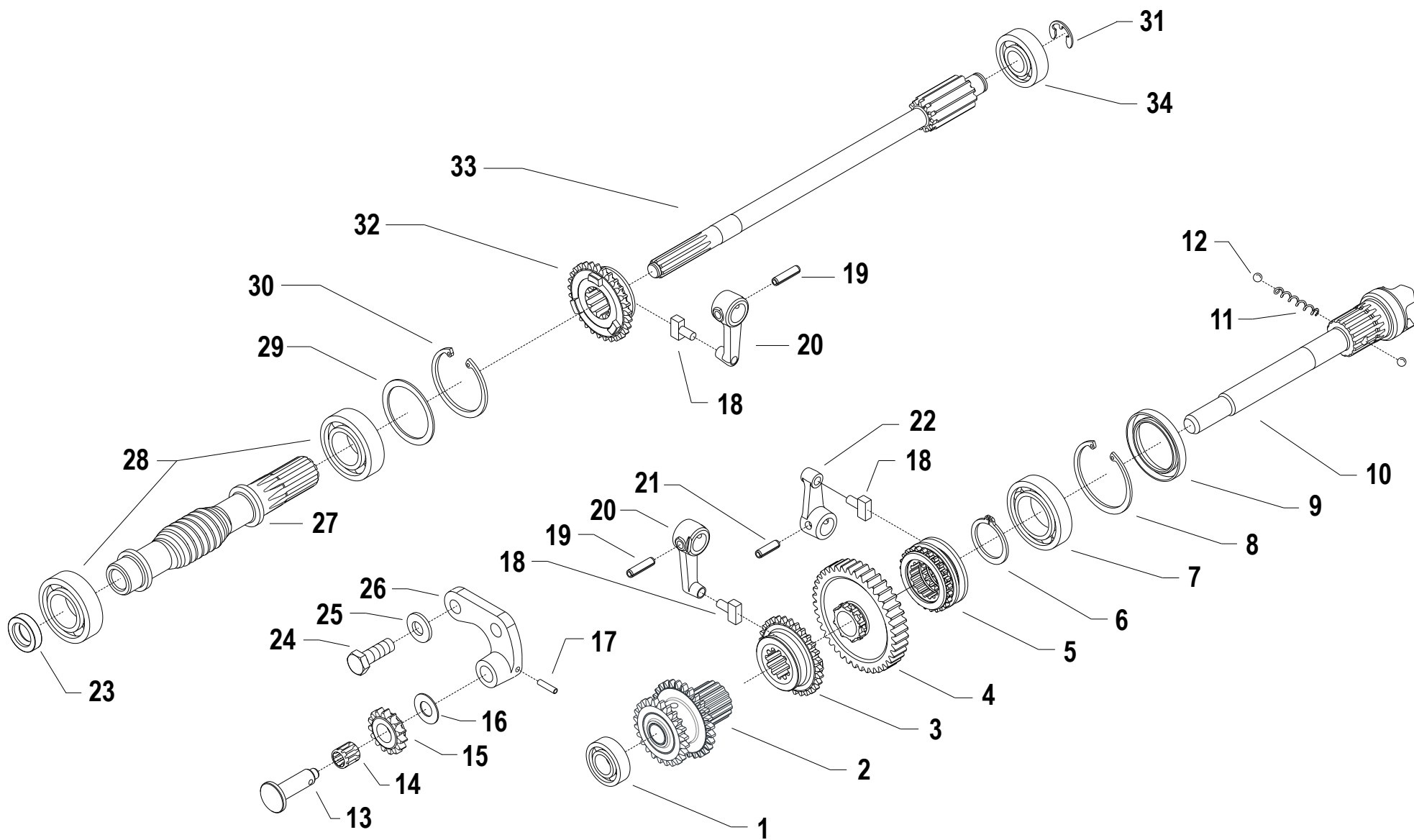

Pos.	Code	Q.ty	Description	Notes
1	37111150		BEARING	
2	59056384		DOUBLE GEAR	
3	52456370		SLIDER	
4	59056707		PTO GEAR	Replaces 59056365 + 52456362
5	52456706		PTO COUPLING	Replaces 59056365 + 52456362
6	35121031		SEEGER RING E 30 UNI 7436	
7	37112229		BEARING	
8	35111055		SEEGER RING I 55 DIN 472	
9	38213800		OIL SEAL 38X55X7	
10	52456335		PTO SHAFT	
11	58056391		SPRING	
12	37910832		BALL 1/4	
13	56456736		PERNO INGRANAGGIO OZIOSO	Replaces 56456351
14	37320120		ROLLER CAGE 12X15/10	
15	56456347		GEAR	
16	56356348		ADJUSTING RING	
17	34211042		ROLL PIN	
18	58043086		SHOE	
19	34213060		ROLL PIN	
20	52456389		LEVER	
21	34213061		ROLL PIN	
22	52456390		LEVER	
23	38211500		OIL SEAL 15X28X7	
24	31112211		SCREW TE M10X30 UNI 5739	
25	31421101		WASHER	
26	52456349		GEAR SUPPORT	
27	56456475		SCREW	
28	37111255		BEARING	
29	56356328		ADJUSTING RING SP=1,5	
29	56356329		ADJUSTING RING SP=1,6	
29	56356330		ADJUSTING RING SP=1,7	
29	56356331		ADJUSTING RING SP=1,8	
30	35111052		SEEGER RING I 52 DIN 472	
31	52456354		GEAR	

SERIAL
START
937702

GEARS

CODE REV

F.02.02.A0027_01

GEARS

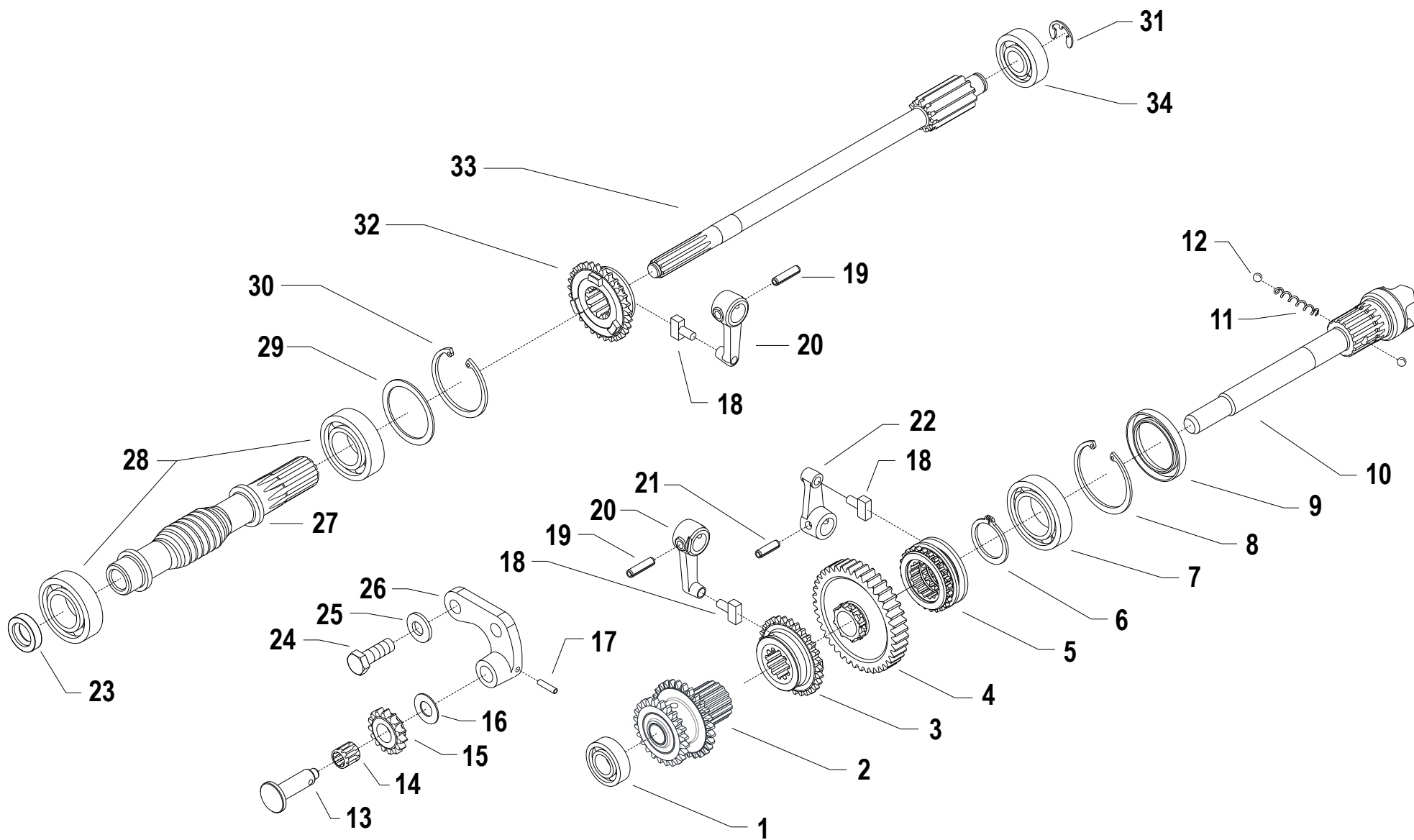

Pos.	Code	Q.ty	Description	Notes
32	52456361		SLIDER	
33	52456339		SHAFT	
34	37111152		BEARING	
35	35211120		SEEGER RING E 12 UNI 7434	

SERIAL
START
937702

GEARS

CODE REV
F.02.02.A0027_01

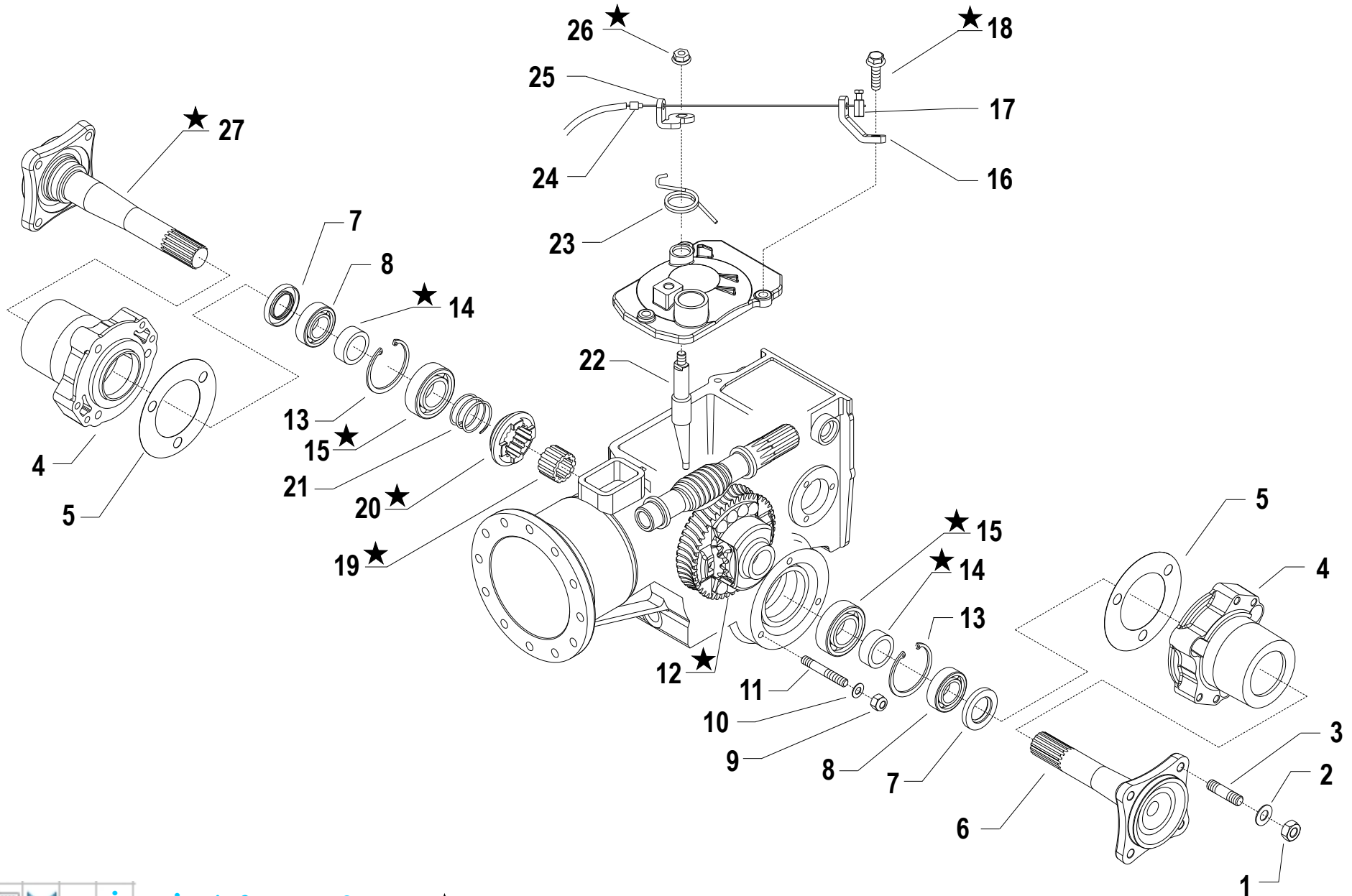

i = info - stop 2 sec. ★ = new part

Pos.	Code	Q.ty	Description	Notes
1	31211100		NUT M10	
2	31423105		SPRING WASHER 10,5	
3	31312102		STUD BOLT M10X40X24X12	
4	53243851N		HUB	
5	58043855		GASKET	
6	52448187N		AXLE SHAFT	
7	38213002		OIL SEAL 30X40X7	
8	37111253		BEARING	
9	31241080		SELFLOCK NUT M8	
10	31423084		SPRING WASHER 8,4	
11	31312080		STUD BOLT M8X46X20X12	
12	59048199		DIFFERENTIAL GEAR	
13	35111047		SEEGER RING I 47 DIN 472	
14	56148184		RING	
15	37111250		BEARING	
16	56143883		STOP	
17	58002429		CLAMPING SCREW	
18	31112167		SCREW TE C/F M8X30 DIN 6921 8G	
19	56448183		SPACER	
20	56448196		COUPLING	
21	58043874		SPRING	
22	56443871		ROD	
23	58043881N		SPRING	
24	58042167		SHEATH TERMINAL	
25	56143880		SMALL LEVER	
26	31241084		SELFLOCK NUT M8 6S	
27	52448188N		AXLE SHAFT	

SERIAL
START
848877

DIFFERENTIAL

CODE REV

G.02.01.A0027_01

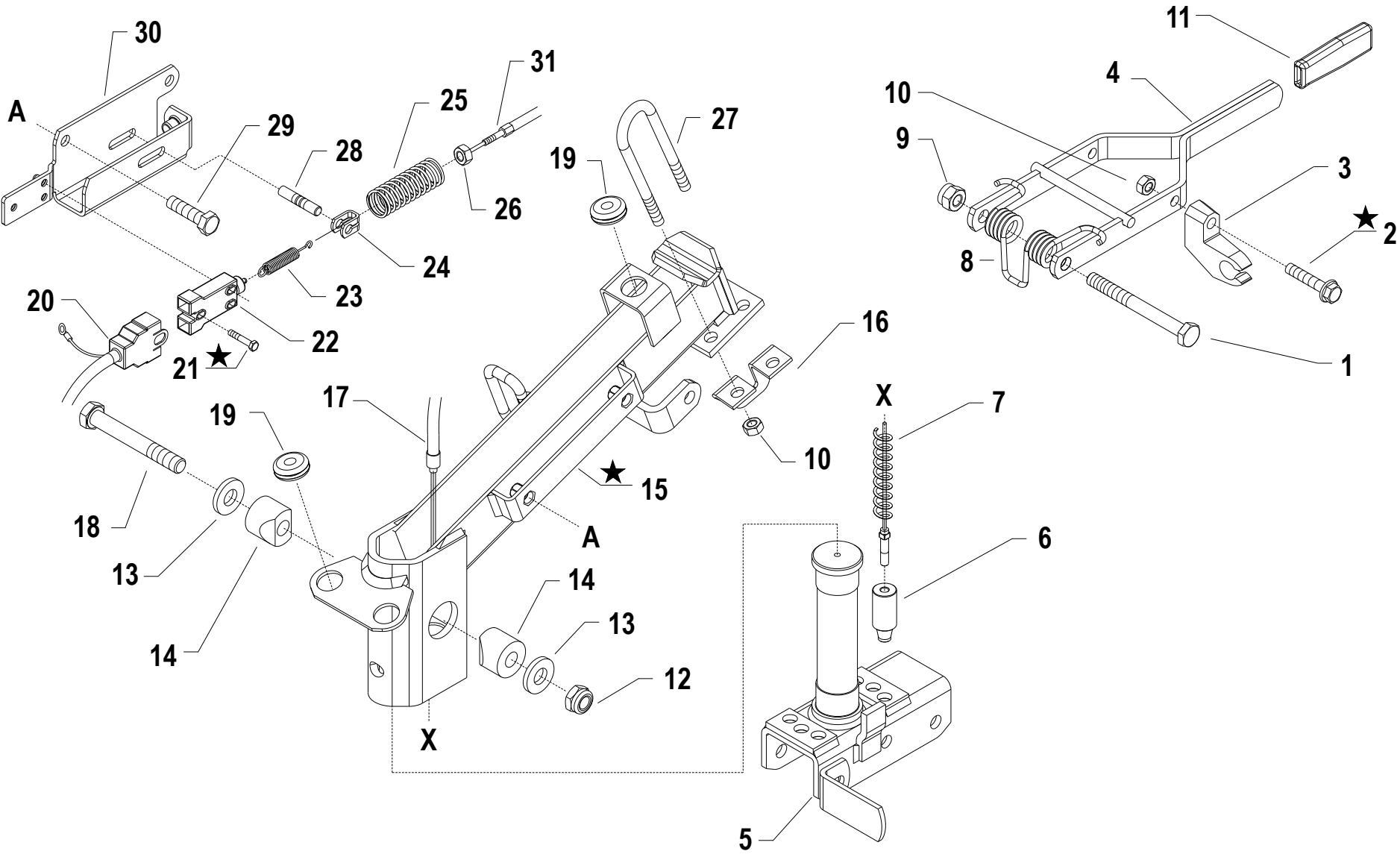

i = info - stop 2 sec. ★ = new part

Pos.	Code	Q.ty	Description	Notes
1	31111229		SCREW TE M10X110 UNI 5737 8G	
2	31112165		SCREW TE C/F M8X35 DIN 6921 8G	
3	55243340		SUPPORT	
4	59056935		LEVER	
5	59056952N		SUPPORT	
6	56356924		FERRULE	
7	58056918Z		SPRING	
8	58056942N		SPRING	
9	31241100		SELFLOCK NUT M10 6S	
10	31241080		SELFLOCK NUT M8	
11	55102714		KNOB	
12	31241126		SELFLOCK NUT M12	
13	31421100Z		CUP SPRING	
14	52156917		WEDGE	
15	59256999		COLUMN	REPLACES 59056995
16	56156948N		STOP	
17	58042167		SHEATH TERMINAL	
18	31112293		SCREW TE M12X80 UNI 5737	
19	58056991		CABLE GLAND	
20	58057417		WIRING	
21	31121024		SCREW TBCEI FL.M4X25	
22	58048009		SWITCH	
23	58047712		SPRING	
24	56157411Z		FORK	
25	58057413		RETAINING SPRING	
26	31211080		NUT M8	
27	56156940		U BOLT	
28	56157412		PIN	
29	31112170		SCREW TE C/F M8X20 DIN 6921	
30	59257409		SUPPORT	
31	58057416		LINE AND SHEATH	

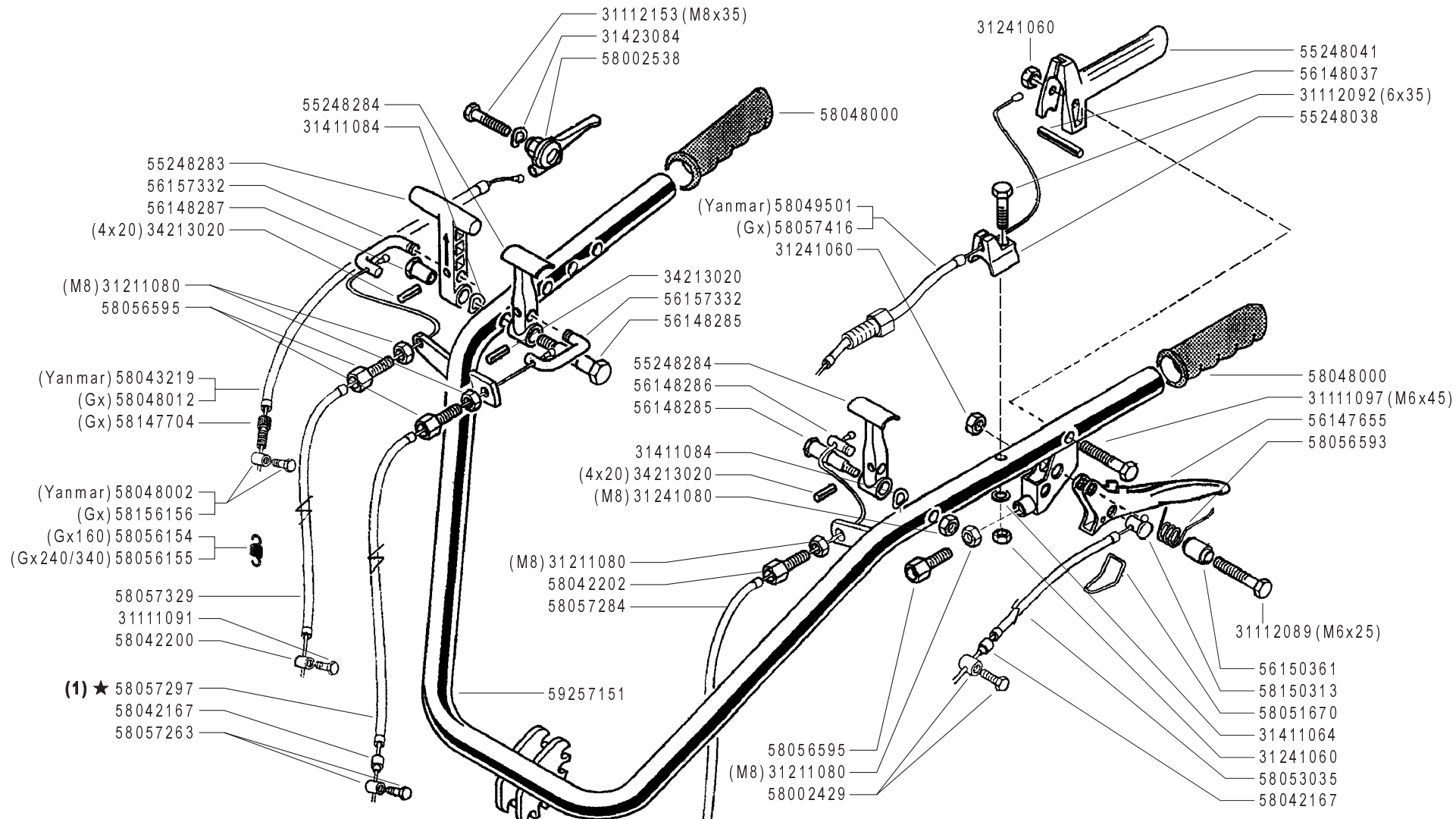

(1) sostituisce 58057286

	<h1>300 TRENDY</h1>	MANUBRIO (320-330) HANDLEBAR MANILLAR	DALLA MACCHINA FROM THE MACHINE DE LA MACHINE DE LA MAQUINA AB DER MASCHINE	AGGIORNAMENTO	I02	Rev.
				REVISION		1
				MISE A JOUR		
				APLAZAMIENTO		
				ANPASSUNG		
			★ N.	06/2007	ZENNE	

Pos.	Code	Q.ty	Description	Notes
31111091	31111091	1	SCREW E M6X14 UNI 5739 8G	
31111097	31111097	1	SCREW TE M6X45 UNI 5737 8G	
31112089	31112089	1	SCREW TE M6X25 UNI 5739 8G	
31112092	31112092	1	SCREW TE M6X35 UNI 5739 8G	
31112153	31112153	1	SCREW TE M8X35 UNI 5739 8G	
31211080	31211080	1	NUT M8	
31241060	31241060	1	SELFLOCK NUT M6	
31241080	31241080	1	SELFLOCK NUT M8	
31411064	31411064	1	WASHER 6,4x12,5	
31411084	31411084	1	WASHER 8,4x17	
31423084	31423084	1	SPRING WASHER 8,4	
34213020	34213020	1	ROLL PIN	
55248038	55248038	1	STOP	
55248041	55248041	1	LEVER	
55248283	55248283	1	COMMAND LEVER	
55248284	55248284	1	LEVER	
56147655	56147655	1	CLUTCH LEVER	
56148037	56148037	1	LEVER STOP	
56148285	56148285	1	PIN	
56148286	56148286	1	PIN	
56148287	56148287	1	STUD BOLT	
56150361	56150361	1	SPACER	
56157332	56157332	1	U BOLT	
58002429	58002429	1	CLAMPING SCREW	
58002538	58002538	1	COMMAND LEVER	
58042167	58042167	1	SHEATH TERMINAL	
58042200	58042200	1	CLAMPING SCREW	
58042202	58042202	1	ADJUSTING SCREW	
58043219	58043219	1	LINE AND SHEATH	
58048000	58048000	1	KNOB	
58048002	58048002	1	CLAMPING SCREW	
58048012	58048012	1	LINE AND SHEATH	
58049501	58049501	1	LINE AND SHEATH	
58051670	58051670	1	CLEVIS	

SERIAL

HANDLEBAR

CODE REV

I02_1_45506

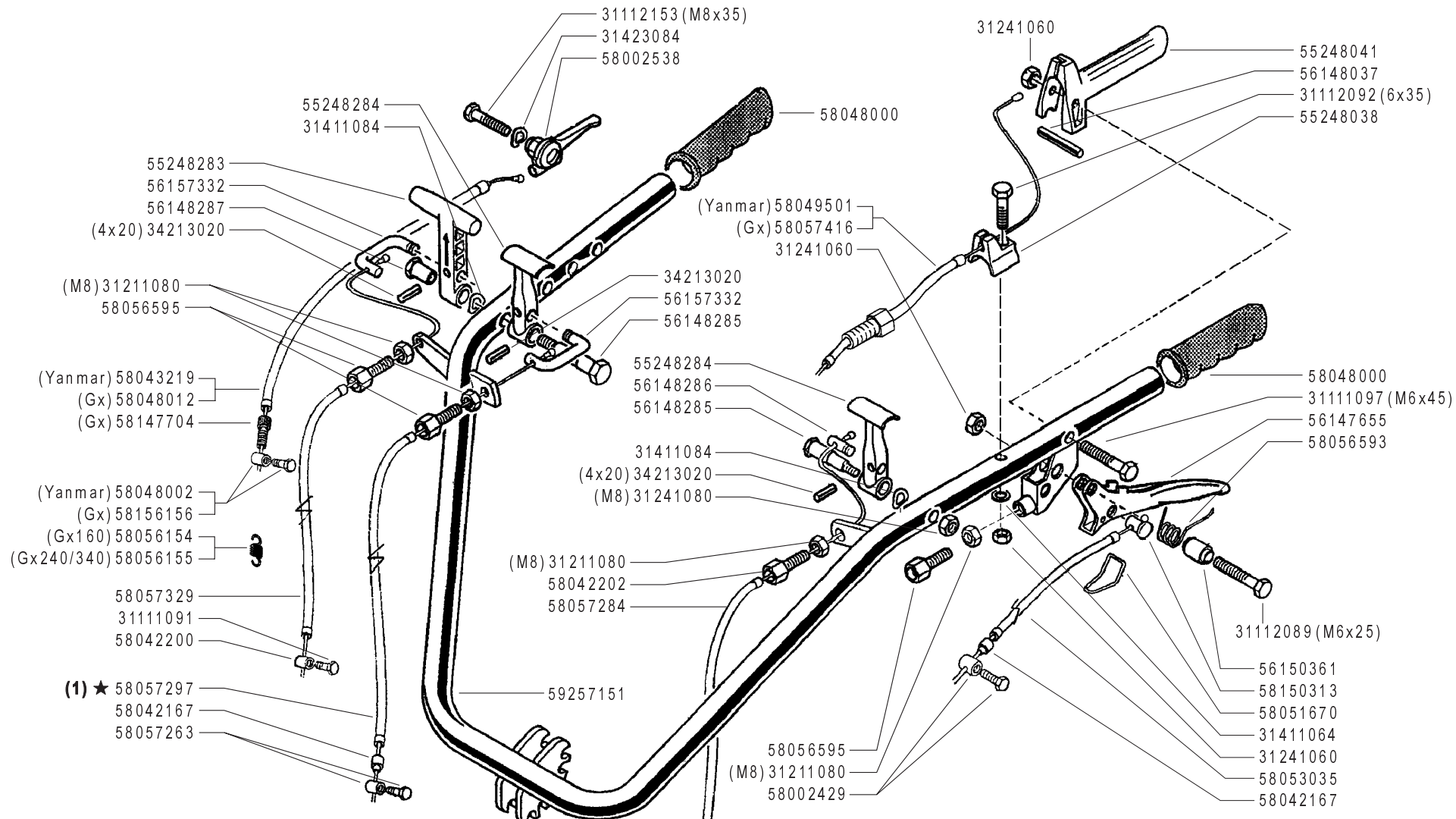

(1) sostituisce 58057286

	<h1>300 TRENDY</h1>	MANUBRIO (320-330) HANDLEBAR MANILLAR	DALLA MACCHINA FROM THE MACHINE DE LA MACHINE DE LA MAQUINA AB DER MASCHINE	AGGIORNAMENTO	I02	Rev.
				REVISION		1
				MISE A JOUR		
				APLAZAMIENTO		
				ANPASSUNG		

★ N.

ZENNE

Pos.	Code	Q.ty	Description	Notes
58053035	58053035	1	LINE AND SHEATH	
58056154	58056154	1	RESTORING SPRING	Utilizzato con motore GX200
58056155	58056155	1	RESTORING SPRING	Utilizzato con motore GX270
58056593	58056593	1	SPRING	
58056595	58056595	1	ADJUSTING SCREW	
58057263	58057263	1	CLAMPING SCREW	
58057284	58057284	1	LINE AND SHEATH	
58057297	58057297	1	LINE AND SHEATH	
58057329	58057329	1	LINE AND SHEATH	
58057416	58057416	1	LINE AND SHEATH	
58147704	58147704	1	ADJUSTING SCREW	
58150313	58150313	1	CABLE CLAMP	
58156156	58156156	1	TERMINAL	
59257151	59257151	1	COMPLETE HANDLE BAR	

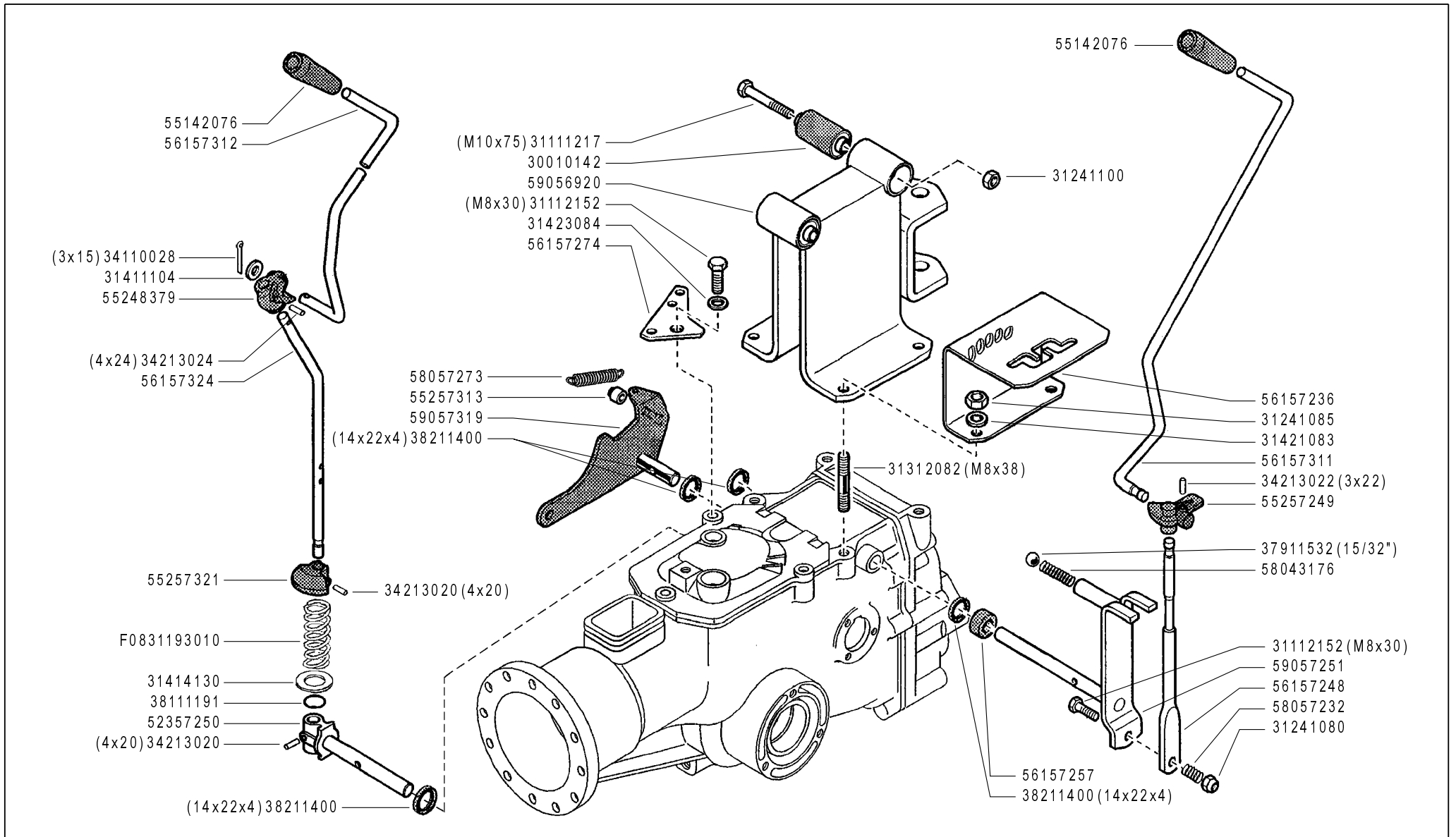

FERRARI

300 TRENDY

COMANDI (320-330)

CONTROLS
MANDOS

COMMANDES
ANTRIEBE

DALLA MACCHINA
FROM THE MACHINE
DE LA MACHINE
DE LA MAQUINA
AB DER MASCHINE

N.

J02 0

11/2006

Rev.

ZENNE

Pos.	Code	Q.ty	Description	Notes
30010142	30010142	1	SILENT-BLOCK 10,2X30X45X49	
31111217	31111217	1	SCREW TE M10X75 UNI 5737 8G	
31112152	31112152	1	SCREW TE M8X30 UNI 5739 8G	
31241080	31241080	1	SELFLOCK NUT M8	
31241085	31241085	1	SELFLOCK NUT M8 6S	
31241100	31241100	1	SELFLOCK NUT M10 6S	
31312082	31312082	1	STUD BOLT M8X38X14X20	
31411104	31411104	1	WASHER 10,5x18	
31414130	31414130	1	WASHER 13	
31421083	31421083	1	WASHER	
31423084	31423084	1	SPRING WASHER 8,4	
34110028	34110028	1	SPLIT PIN	
34213020	34213020	1	ROLL PIN	
34213022	34213022	1	ROLL PIN	
34213024	34213024	1	ROLL PIN	
37911532	37911532	1	BALL 15/32	
38111191	38111191	1	O-RING 115 (11,91X2,62)	
38211400	38211400	1	OIL SEAL 14X22X4	
52357250	52357250	1	PIN	
55142076	55142076	1	KNOB	
55248379	55248379	1	JOINT	
55257249	55257249	1	JOINT	
55257313	55257313	1	ROLLER	
55257321	55257321	1	STOP	
56157236	56157236	1	GEAR SELECTOR	
56157248	56157248	1	COMMAND LEVER	
56157257	56157257	1	SPACER	
56157274	56157274	1	SQUARE	
56157311	56157311	1	GEARSHIFT ROD	
56157312	56157312	1	ROD	
56157324	56157324	1	PTO LEVER	
58043176	58043176	1	SPRING	
58057232	58057232	1	SPRING	
58057273	58057273	1	SPRING	

SERIAL

CONTROLS

CODE REV

J02_0_27474

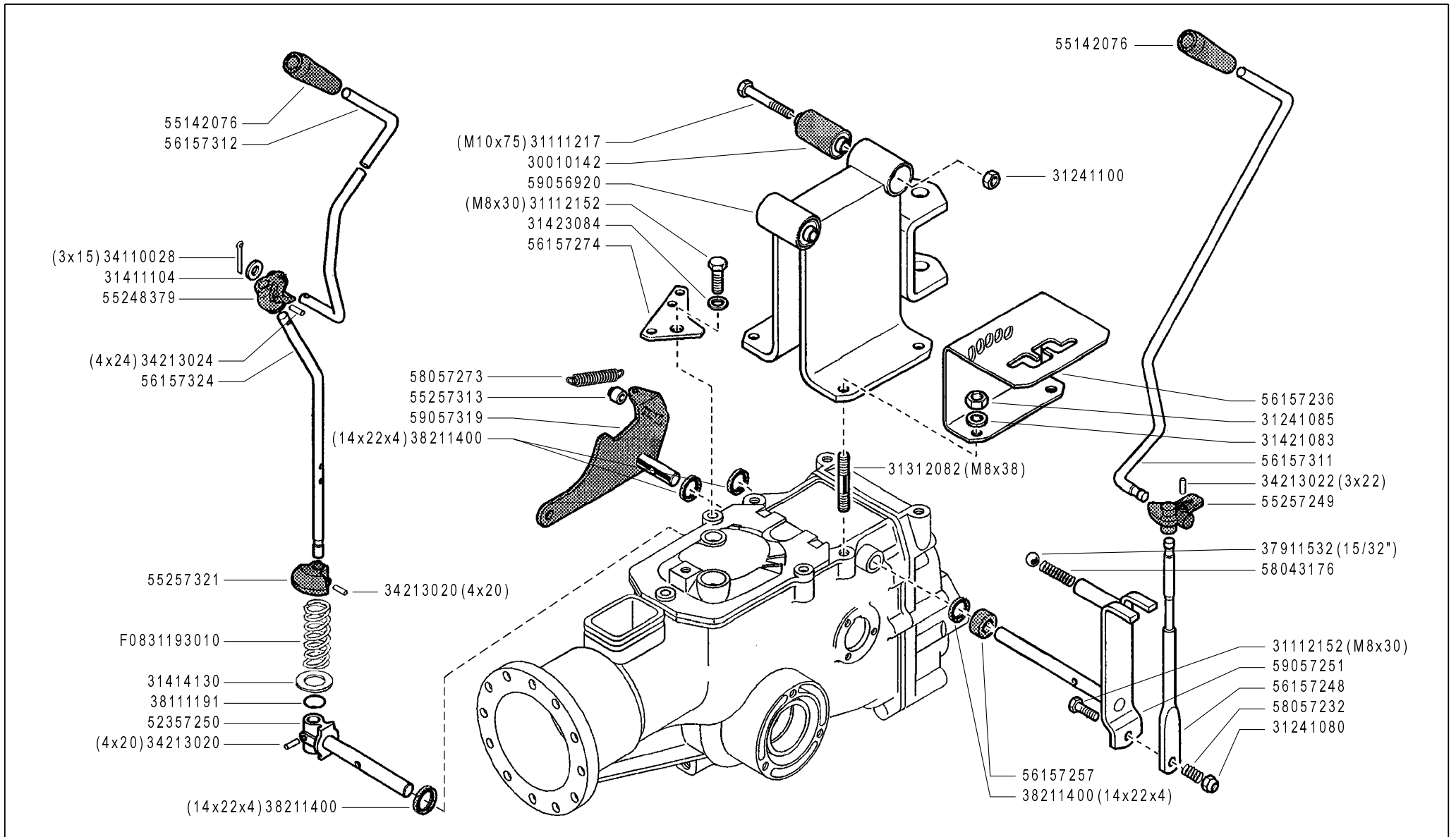

FERRARI

300 TRENDY

COMANDI (320-330)

CONTROLS
MANDOS

COMMANDES
ANTRIEBE

DALLA MACCHINA
FROM THE MACHINE
DE LA MACHINE
DE LA MAQUINA
AB DER MASCHINE

N.

J02 0

11/2006

Rev.

ZENNE

Pos.	Code	Q.ty	Description	Notes
59056920	59056920	1	SUPPORT	
59057251	59057251	1	GEAR LEVER	
59057319	59057319	1	LEVER	
F0831193	F0831193010	1	SPRING DM.15X70	

	A	B	C	D	
	3.50 - 8"	39113502	39413502	58052326	92243686 (Kg.10)
	4.00 - 8"	39114008	39414008	58052326	92243686 (Kg.10)
★	4.0 - 10"	39114010	39414010	58052288 (FIX)	/
	4.0 - 10"	39114010	39414010	58052327	92248715 (Kg.15)
★	5.0 - 10"	39115010	39415010	58052288 (FIX)	/
	5.0 - 10"	39115010	39415010	58052327	92248715 (Kg.15)
	5.00 - 12"	39115012	39415012	58052328	92248720 (Kg.34)
★	6.5/80 - 12"	39116018	39416018	58052328	92480721 (Kg.34)

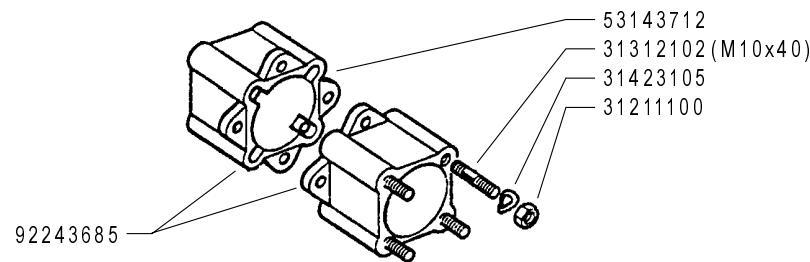
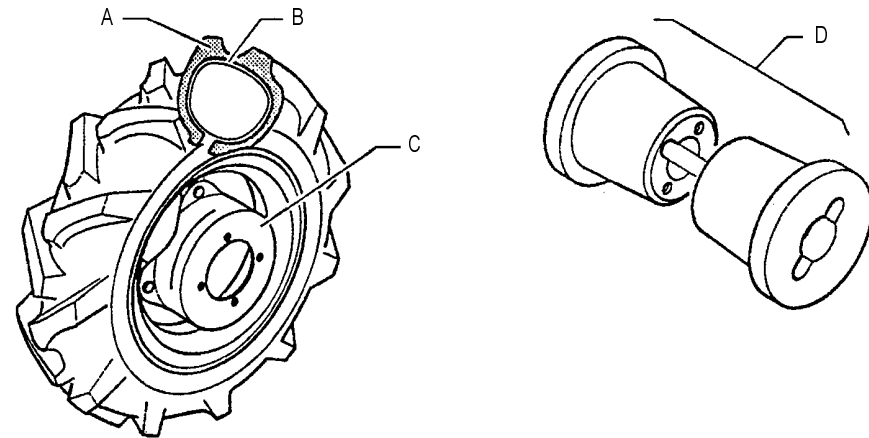

FERRARI

300 TRENDY

RUOTE

WHEELS
RUEDAS

ROUES
RÄDER

DALLA MACCHINA
FROM THE MACHINE
DE LA MACHINE
DE LA MAQUINA
AB DER MASCHINE

★ N.

AGGIORNAMENTO
REVISION
MISE A JOUR
APLAZAMIENTO
ANPASSUNG

K01

Rev. **1**

10/2008

ZENNE

Pos.	Code	Q.ty	Description	Notes
31211100	31211100	1	NUT M10	
31312102	31312102	1	STUD BOLT M10X40X24X12	
31423105	31423105	1	SPRING WASHER 10,5	
39113502	39113502	1	TYRE 3.50-8 2PR	
39114008	39114008	1	TYRE 4.00-8 2PR	
39114010	39114010	1	TYRE 4.0-10 2PR	
39115010	39115010	1	TYRE 5.00-10 2PR	
39115012	39115012	1	TYRE 5.00-12 2PR	
39116018	39116018	1	TYRE 6.5/80-12 2PR	
39413502	39413502	1	INNER TUBE	
39414008	39414008	1	INNER TUBE	
39414010	39414010	1	INNER TUBE	
39415010	39415010	1	INNER TUBE	
39415012	39415012	1	INNER TUBE	
39416018	39416018	1	INNER TUBE	
53143712	53143712	1	SPACER	
58052288	58052288	1	RIM	
58052326	58052326	1	RIM	
58052327	58052327	1	RIM	
58052328	58052328	1	RIM	
92243685	92243685	1	PAIR WHEEL SPACERS 6 CM	
92243686	92243686	1	PAIR OF WEIGHTS FOR 8 WHEELS 11 KGS	
92248715	92248715	1	PAIR OF WEIGHTS FOR 10 WHEELS 15 KGS	
92248720	92248720	1	PAIR OF WEIGHTS FOR 12 AND 15 WHEELS - 34 KGS	
92480721	92480721	1	WEIGHTS KG. 34 FOR WHEELS 5.00-12 / 6.5/80-12 (PAIR) (0901012307)	