

PARTS LIST

HONDA ENGINE

GX120U1

FOR MIKASA PRODUCTS

805-02402

FOR MODEL

MVH-R60A/60HW/AH
HYDRAULIC REVERSIBLE SOIL COMPACTOR

MVC-64H/F60H
VIBRATING PLATE COMPACTOR

GX120U1 - SM12 : FOR MQ

GX120U1 - SM14 : FOR EU / EXPORT

GX120U1 - QMX2 : FOR MQ(INCHI)

MVH-R60H/H,MVC-64H

MVH-R60,MVC-F60H/62H

MVC-60H

MIKASA SANGYO CO.,LTD.

PARTS REMARK INDEX

How to read the marks and remarks used in this parts book.

Section 1 : Explanation of Code Use In “MRK” Column

OO : Interchangeable between the new part and the old one.

XX : Not Interchangeable between new and old.

OX : New part is usable for the old machine but the old part is not usable for the new machine.

XO : The old part is usable for the new machine but the new part is not usable for the old machine.

Note : In case of the lack of interchangeability between the new part and old part, a new part may be used by replacing all other parts found in the assembly. In this case, refer to section 2 for instruction on identifying other parts involved in a new assembly.

AD : Newly established(added)

DC : Suspended(discontinued)

NC : Part number changed

QC : Quantity used has been changed

NS : Not supplied individually but supplied in an assembly or a group.

AS : Special part designed to allow interchangeability between new and old part.

CR : Correction

Section 2 : Items Found In “Remark” Column

Serial Numbers - Where indicated, this indicates a serial number range (inclusive) where a particular part is used.

Model Number - Where indicated, this shows that the corresponding part is utilized only with this specific model number or model number variant.

or * : All parts with the same number following # or * belong to the same assembly. this part cannot be interchanged individually with any other assemblies to replace an old part (indicated by #), with a new part(indicated by *), then all other parts of that assembly must be replaced with new ones.

Note : If more than one of the same reference number is listed, the last one listed indicates newest(or latest)part available.

Section 3: Example

REF NO.	PART NO.	PART NAME	QTY	MRK	REMARKS
457(1)	5122-09230	Hinge Metal, Upper/24g	1		-1070 #3 (5)
457(2)	5072-09420	Hinge Metal, Upper M16	1	OX(3)	U1071-(6) * 3(7)

(1) Old part

(2) New part

(3) New part usable with old machine, but old part not usable with new machine (reference section 1).

(4) Old part number is used through this machine serial number.

(5) Old part, used in an assembly with other parts marked with #3. To use this part on a new machine, all other parts in this assembly must be replaced with old ones.

(6) New part put into use starting with this serial number and is still current.

(7) New part used in an assembly with other parts marked * 3, to use this part as a replacement for an old part, all other * 3 marked parts must be changed at the same time.

Section 4: Items Found In “MK2” Column

(only for suspended products)

! OO (“OO” is shown in figure) : The part shown in lower line is supplied.

! SD : Not available due to termination of production.

! NS : Not supplied individually, but supplied in an assembly or a group.

! PD : Supplied as unit product.

SS : Not available after stock run out.

(The contents of this parts catalog are subject to change without notice.)

CYLINDER HEAD

E-2

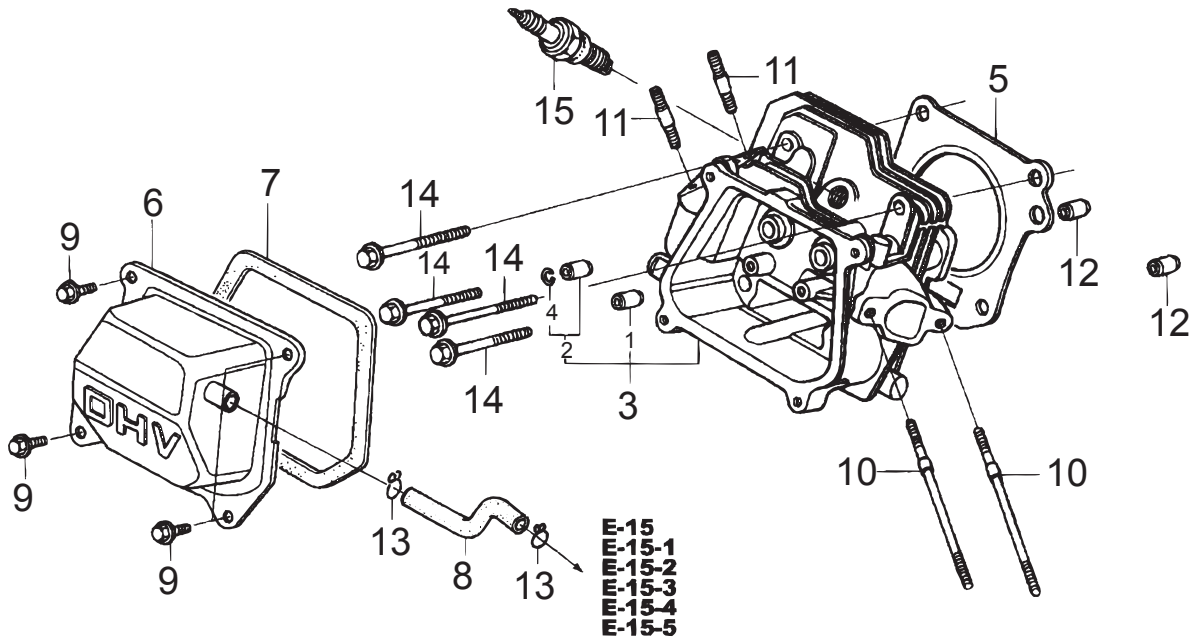

Z4F0-E0200M **FR.** →

GX120U1-SM12 :for MQ MVH-R60H/HW, MVC-64H/HW
 GX120U1-SM14 :for EU / EXPORT MVH-R60, MVC-F60H/62H
 GX120U1-QMX2 :for MQ (INCHI) MVC-60H

2010/4/30

**** APF ****

REF NO.	PART NO.	PART NAME	Q' TY	MRK	MK2	REMARKS
1	12204-ZE1-306	GUIDE, INLET VALVE (O. S.)	(1)			
2	12205-ZE1-315	GUIDE, EXHAUST VALVE (O. S.)	(1)			
3	12210-ZH7-415	HEAD CP, CYLINDER/GX120	1			
4	12216-ZE5-300	CLIP, VALVE GUIDE	1			
5	12251-ZH7-800	GASKET, CYLINDER HEAD	1			
6	12310-ZE1-020	COVER COMP, HEAD	1			
7	12391-ZE1-000	PACKING, HEAD COVER	1			
8	15721-ZH8-000	TUBE, BREATHER	1			
9	90013-883-000	FLANGE BOLT 6X12	4			
10	90043-ZE1-020	STUD BOLT 6X112	2			
11	90047-ZE1-000	STUD BOLT 8X32	2			
12	94301-10160	KNOCK PIN 10X16	2			
14	95723-0805500	FLANGE BOLT 8X55	4			
15	065-01404-80	SPARK PLUG EY45V	1			

E-3

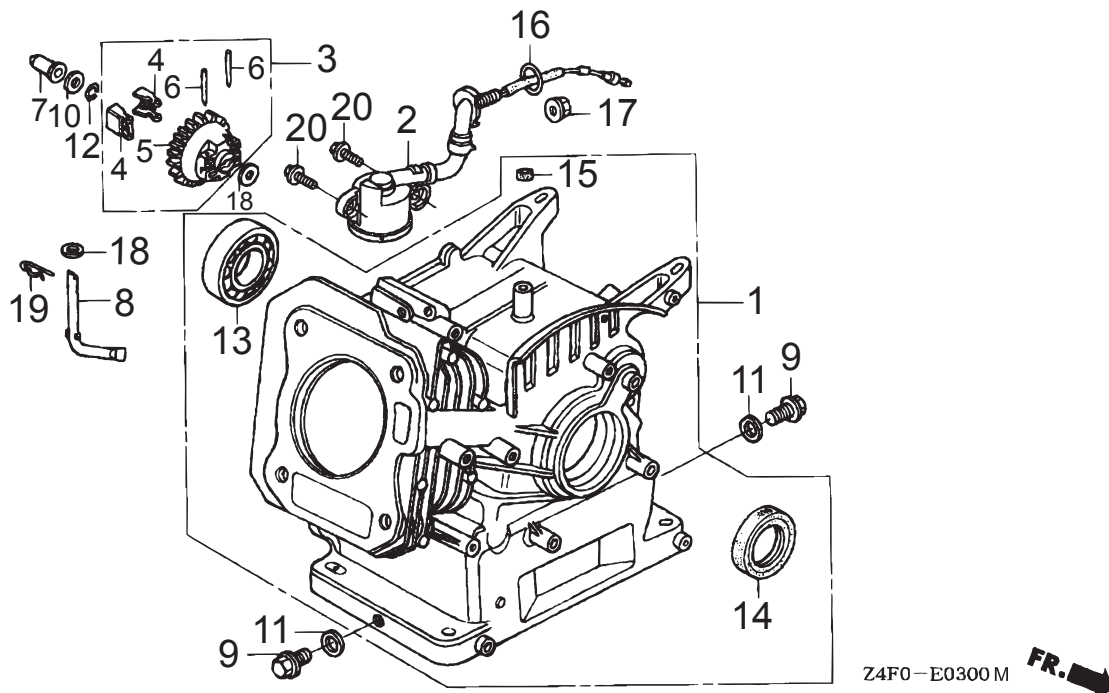

GX120U1-SM12 :for MQ MVH-R60H/HW, MVC-64H/HW
 GX120U1-SM14 :for EU / EXPORT MVH-R60, MVC-F60H/62H
 GX120U1-QMX2 :for MQ (INCHI) MVC-60H

2010/4/30

** APG **

REF NO.	PART NO.	PART NAME	Q' TY	MRK	MK2	REMARKS
1	12000-ZH7-425	BARREL ASSY., CYLINDER	1			
2	15510-ZE1-033	SWITCH ASSY., OIL LEVEL	1			SS!15510-ZE1-043
2	35480-Z0T-003	SWITCH ASSY., OIL LEVEL	1			1173452-
3	16510-ZE1-000	GOVERNOR ASSY.	1			
4	16511-ZE1-000	WEIGHT, GOVERNOR	2			
5	16512-ZE1-000	HOLDER, GOVERNOR WEIGHT	1			
6	16513-ZE1-000	PIN, GOVERNOR WEIGHT	2			
7	16531-ZE1-000	SLIDER, GOVERNOR	1			
8	16541-ZE1-000	SHAFT, GOVERNOR ARM	1			
9	90131-ZE1-000	BOLT, DRAIN PLUG	2			
10	90451-ZE1-000	THRUST WASHER 6MM	1			
11	90601-ZE1-000	WASHER, DRAIN PLUG	2			
12	90602-ZE1-000	CLIP, GOVERNOR HOLDER	1			
13	91001-878-003	BALL BEARING 62/22	1			
14	91202-ZE6-013	OIL SEAL 22X35X6 /GX120	1			
16	91353-671-004	O-RING 14MM	1			
17	94050-10000	FLANGE NUT M10	1			
18	94101-06800	PLAIN WASHER 6MM	2			
19	94251-08000	LOCK PIN 8MM	1			
20	95701-0601200	FLANGE BOLT 6X12	2			

GX120U1 (for Mikasa)

CRANKCASE COVER

E-6

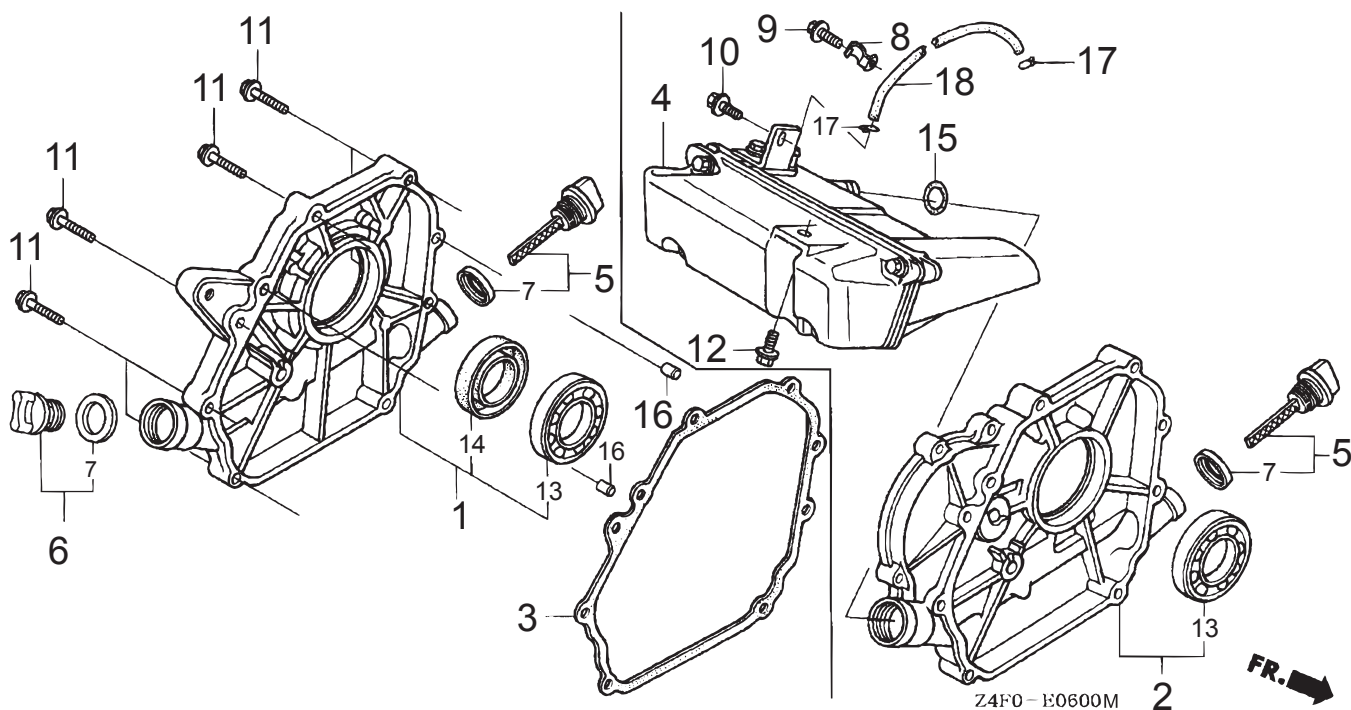

GX120U1-SM12 :for MQ MVH-R60H/HW, MVC-64H/HW
 GX120U1-SM14 :for EU / EXPORT MVH-R60, MVC-F60H/62H
 GX120U1-QMX2 :for MQ (INCHI) MVC-60H

2010/4/30

** APH **

REF NO.	PART NO.	PART NAME	Q' TY	MRK	MK2	REMARKS
1	11300-ZE0-634	COVER ASSY., CRANKCASE	1			SM12, SM14
1	11300-ZE0-641	COVER ASSY., CRANKCASE	1			QMX2
3	11381-ZH7-800	GASKET, CRANK CASE	1			
5	15600-ZE1-003	OIL GAUGE	1			
6	15600-ZG4-003	OIL PLUG	1			
7	15625-ZE1-003	PACKING, OIL FILLER CAP	2			
11	90015-883-000	FLANGE BOLT 6X28	7			
13	91001-878-003	BALL BEARING 62/22	1			
14	91203-ZE0-013	OIL SEAL 22X41X6 /GX120	1			
16	94301-08140	KNOCK PIN 8X14	2			

CRANKSHAFT

E-7

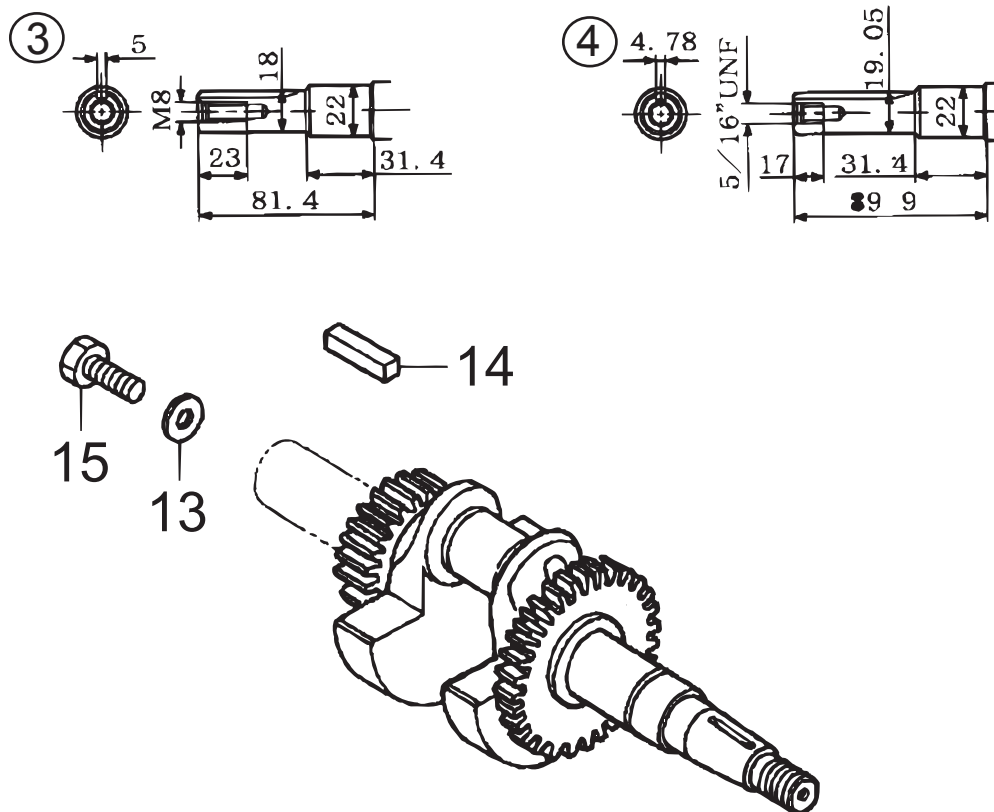

Z4F0-E0700M



GX120U1-SM12 :for MQ MVH-R60H/HW, MVC-64H/HW
 GX120U1-SM14 :for EU / EXPORT MVH-R60, MVC-F60H/62H
 GX120U1-QMX2 :for MQ (INCHI) MVC-60H

2010/4/30

** API **

REF NO.	PART NO.	PART NAME	Q' TY	MRK	MK2	REMARKS
3	13310-ZE0-000	CRANK SHAFT COMP.	1			SM12, SM14
4	13310-ZE0-601	CRANK SHAFT COMP.	1			QMX2
13	90473-842-000	WASHER 8MM	1			SM12, SM14
14	90741-883-810	KEY 5X5X33	1			SM12, SM14
15	92101-080250A	BOLT 8X25	1			SM12, SM14

PISTON/CONNECTING ROD

E-8

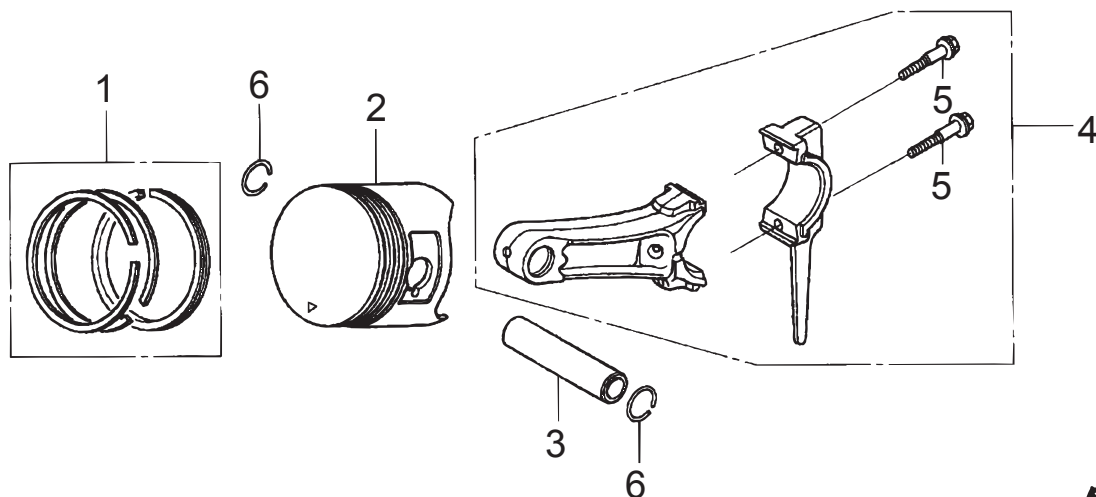

Z4F0-E0800M



GX120U1-SM12 :for MQ MVH-R60H/HW, MVC-64H/HW
 GX120U1-SM14 :for EU / EXPORT MVH-R60, MVC-F60H/62H
 GX120U1-QMX2 :for MQ (INCHI) MVC-60H

2010/4/30

** APJ **

REF NO.	PART NO.	PART NAME	Q' TY	MRK	MK2	REMARKS
1	13010-ZH7-003	RING SET, PISTON STD/GX120	1			
1	13010-Z4F-004	RING SET (STD/GX-120U1	1	XX		1085093-
1	13011-ZH7-003	RING SET, PISTON 0.25 OS	1			
1	13011-Z4F-004	RING SET (0.25/GX120U1	1	XX		1085093-
1	13012-ZH7-003	RING SET, PISTON 0.50 OS	1			
1	13012-Z4F-004	RING SET (0.50/GX120U1	1	XX		1085093-
1	13013-ZH7-003	RING SET, PISTON 0.75 OS	1			
1	13013-Z4F-004	RING SET (0.75/GX120U1	1	XX		1085093-
2	13101-ZH7-010	PISTON STD/GX120	1			
2	13101-ZH7-020	PISTON (STD/GX120U1	1	XX		1085093-
2	13102-ZH7-010	PISTON 0.25	1			
2	13102-ZH7-020	PISTON (1	XX		1085093-
2	13103-ZH7-010	PISTON 0.50	1			
2	13103-ZH7-020	PISTON (0.50/GX120U1	1	XX		1085093-
2	13104-ZH7-010	PISTON 0.75	1			
2	13104-ZH7-020	PISTON (0.75/GX120U1	1	XX		1085093-
3	13111-ZE0-000	PISTON PIN	1			
4	13200-ZE0-000	CONNECTING ROD ASSY.	1			
5	90001-ZE1-000	CONNECTING ROD BOLT	2			
6	90551-ZE0-000	CLIP, PISTON PIN 13MM	2			

GX120U1 (for Mikasa)

CAMSHAFT

E-9

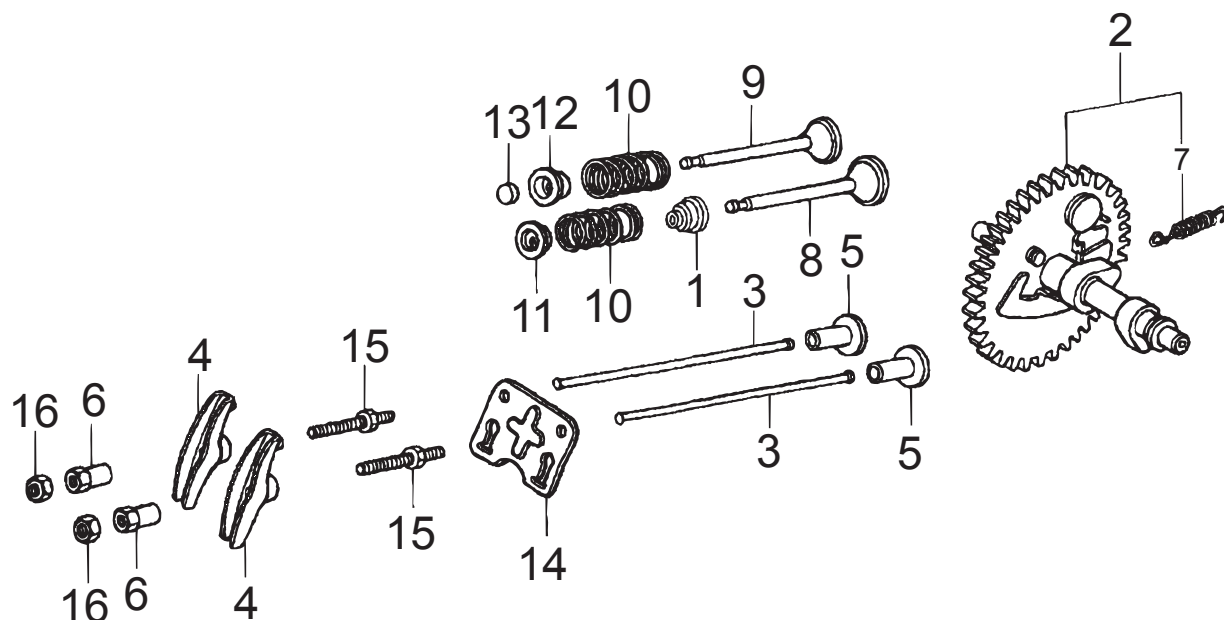

Z4F0-E0900M



GX120U1-SM12 :for MQ MVH-R60H/HW, MVC-64H/HW
 GX120U1-SM14 :for EU / EXPORT MVH-R60, MVC-F60H/62H
 GX120U1-QMX2 :for MQ (INCHI) MVC-60H

2010/4/30

**** APK ****

REF NO.	PART NO.	PART NAME	Q' TY	MRK	MK2	REMARKS
1	12209-ZH8-003	SEAL, VALVE STEM	1			
2	14100-ZE0-812	CAM SHAFT ASSY.	1			
3	14410-ZE0-010	PUSH ROD	2			
4	14431-ZE1-000	ARM, VALVE ROCKER	2			
5	14441-ZE1-010	VALVE LIFTER	2			
6	14451-ZE1-013	PIBOT, ROCKER ARM	2			
7	14568-ZE1-000	SPRING, WEIGHT RETURN	1			
8	14711-ZF0-010	INLET VALVE	1			
9	14721-ZF0-000	EXHAUST VALVE	1			
10	14751-ZF1-000	SPRING, VALVE	2			
11	14771-ZE1-000	RETAINER, INTAKE VALVE	1			
12	14773-ZE1-000	RETAINER, EXHAUST VALVE	1			
13	14781-ZE1-000	ROTATOR, VALVE	1			
14	14791-ZE0-010	PLATE, PUSH ROD GUIDE	1			
15	90012-ZE0-010	PIBOT BOLT 8MM	2			
16	90206-ZE1-000	NUT, PIBOT ADJUSTING	2			

GX120U1 (for Mikasa)

RECOIL STARTER

E-11

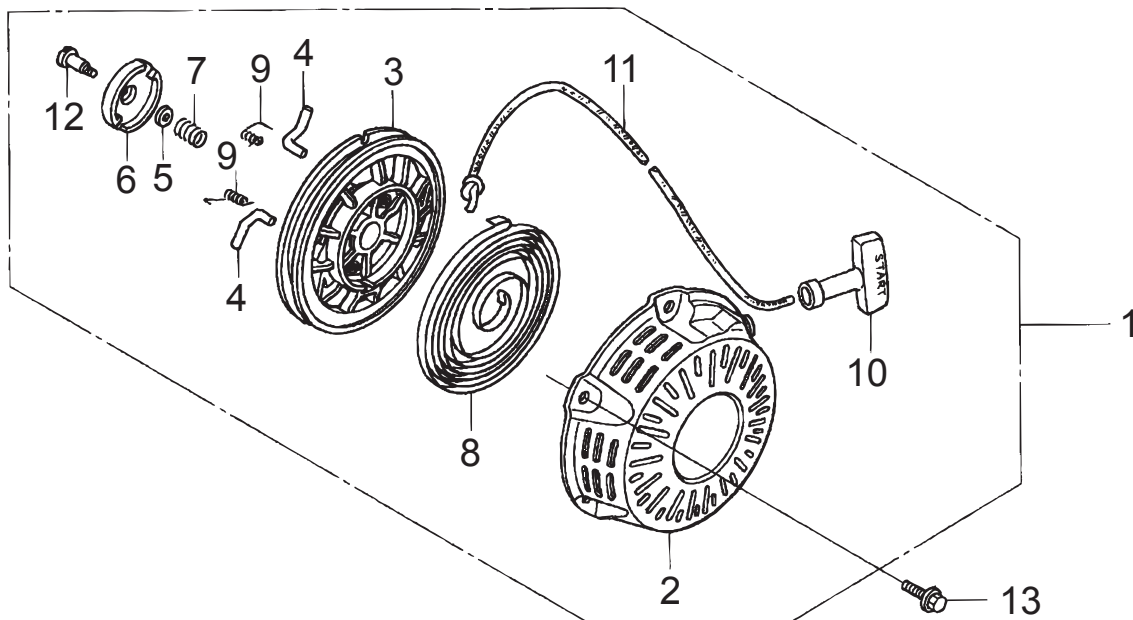

Z4F0-E1100M



GX120U1-SM12 :for MQ MVH-R60H/HW, MVC-64H/HW
 GX120U1-SM14 :for EU / EXPORT MVH-R60, MVC-F60H/62H
 GX120U1-QMX2 :for MQ (INCHI) MVC-60H

2010/4/30

** APL **

REF NO.	PART NO.	PART NAME	Q' TY	MRK	MK2	REMARKS
1	28400ZH8033YA	RECOIL STARTER AY/GX160	1			QMX2
1	28400ZH8023ZB	RECOIL STARTER AY/GX200 (B)	1		SS!28	QMX2, SM12/14
2	28410ZH8003YA	CASE COMP., STARTER	1			QMX2
2	28410ZH8003ZB	CASE COMP., STARTER	1			QMX2, SM12/14
3	28421-ZH8-801	REEL, RECOIL STARTER	1			
4	28422-ZH8-801	RATCHET, STARTER	2			
5	28431-ZH8-801	PLATE, FRICTION	1			
6	28433-ZH8-801	RATCHET GUIDE	1			
7	28441-ZH8-801	FRICTION SPRING	1			
8	28442-ZH8-003	SPRING, RECOIL STARTER	1			
9	28443-ZH8-801	SPRING, RETURN	2			
10	28461-ZH8-013	KNOB, STARTER	1			
11	28462-ZH8-003	ROPE, RECOIL STARTER	1			
12	90003-ZH8-801	SET SVREW	1			
13	90008-ZE2-003	BOLT, FLANGE 6X10	3			

FAN COVER

E-12

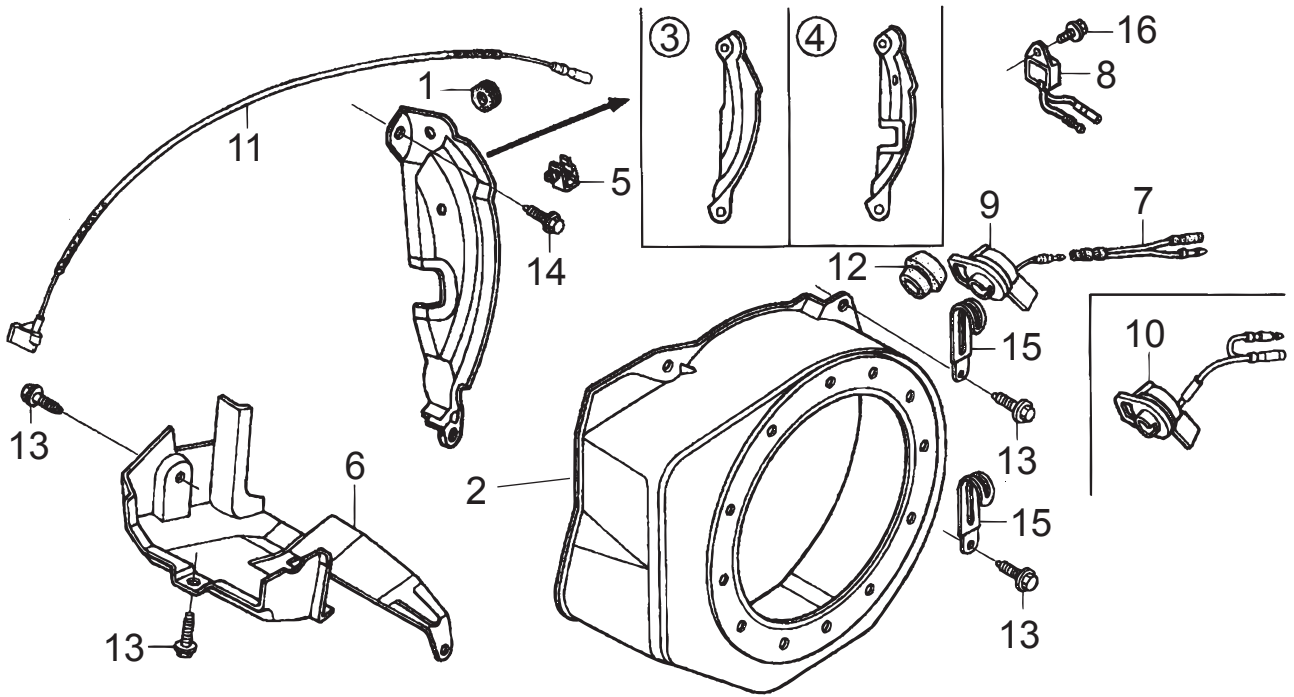

Z4F0-E1200M



GX120U1-SM12 :for MQ MVH-R60H/HW, MVC-64H/HW
 GX120U1-SM14 :for EU / EXPORT MVH-R60, MVC-F60H/62H
 GX120U1-QMX2 :for MQ (INCHI) MVC-60H

2010/4/30

** APM **

REF NO.	PART NO.	PART NAME	Q' TY	MRK	MK2	REMARKS
1	11347-371-300	GROMMET	1			
2	19610ZE0000ZE	FAN COVER CP., BLACK	1			QMX2, SM12/14
2	19610ZE0000ZS	FAN COVER CP., P-RED	1			QMX2
3	19611-ZH7-810	PLATE COMP., SIDE	1			
5	90601-ZH7-013	CLIP, HARNESS	1			
6	19630-ZH7-000	SHROUD COMP.	1			
8	34150-ZH7-013	ALERT, UNIT, OIL	1			
10	36100-ZF6-P82	SWITCH, ASSY, E/G STOP	1			
11	36101-ZE1-010	CORD, STOP SWITCH 370MM	1			
13	90013-883-000	FLANGE BOLT 6X12	6			
14	90022-888-010	FLANGE BOLT 6X20	1			
16	95701-0600800	FLANGE BOLT 6X8	1			

E-14

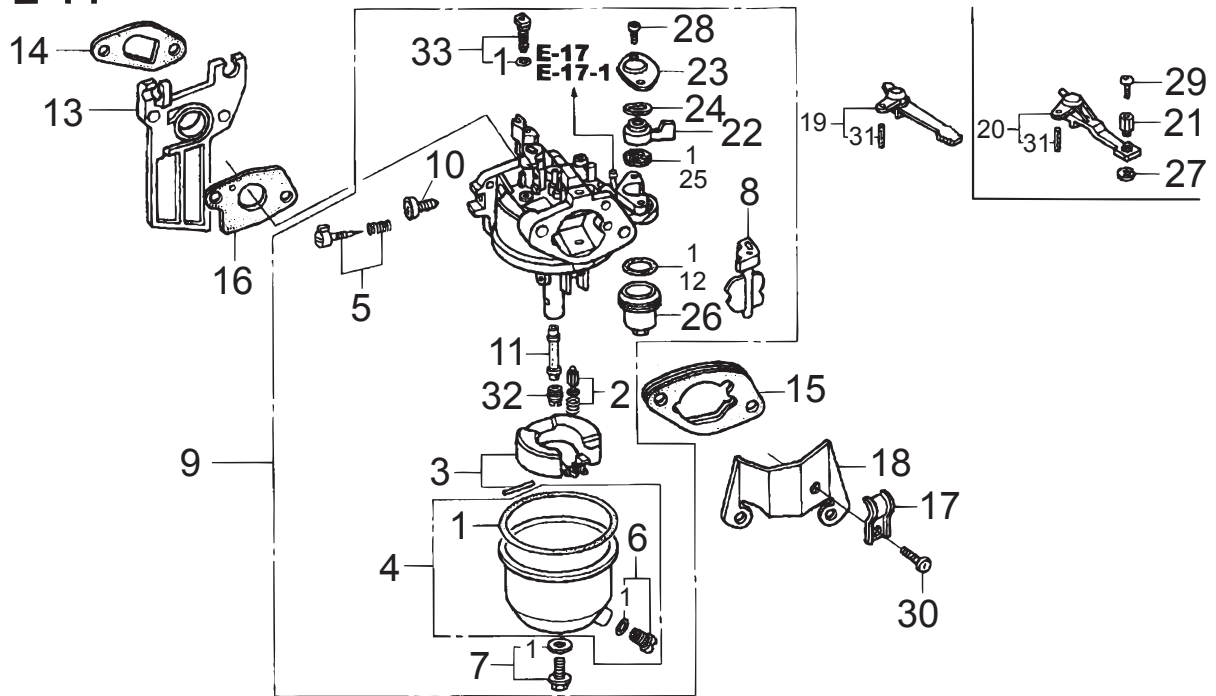

Z4F0-E1400M



- GX120U1-SM12 :for MQ MVH-R60H/HW, MVC-64H/HW
- GX120U1-SM14 :for EU / EXPORT MVH-R60, MVC-F60H/62H
- GX120U1-QMX2 :for MQ (INCHI) MVC-60H

2010/4/30

** APN **

REF NO.	PART NO.	PART NAME	Q' TY	MRK	MK2	REMARKS
1	16010-ZE1-812	GASKET SET	1			
2	16011-ZE0-005	FLOAT VALVE SET	1			
3	16013-ZE0-005	FLOAT SET	1			
4	16015-ZE0-831	FLOAT CHAMBER SET	1			
5	16016-ZH7-W01	SCREW SET, PILOT	1			
6	16024-ZE1-811	DRAIN SCREW SET	1			
7	16028-ZE0-005	SCREW SET	1			
8	16044-ZE0-005	CHOKE SET	1			
9	16100-ZH7-W51	CARBURETOR ASSY. (BE60B B)	1			
10	16124-ZE0-005	SCREW, THROTTLE STOP	1			
11	16166-ZH7-W50	MAIN NOZZLE	1			
12	16173-001-004	PACKING, CUP	1			
13	16211-ZE0-000	INSULATOR, CARBURETOR	1			
14	16212-ZH7-800	PACKING, INSULATOR	1			
15	16220-ZE1-020	SPACER COMP., CARBURETOR	1			
16	16221-ZH8-801	PACKING, CARBURETOR	1			
19	16610-ZE1-000	CHOKE LEVER COMP.	1			
22	16953-ZE1-812	LEVER, COCK	1			
23	16954-ZE1-812	PLATE, LEVER SETTING	1			
24	16956-ZE1-811	SPRING, COCK LEVER	1			
25	16957-ZE1-812	PACKING, FUEL COCK	1			
26	16967-ZE0-811	CUP, FUEL STRAINER	1			
28	93500-030060H	SCREW 3X6 / GX390	2			
31	94305-20122	SPRING PIN 2X12	1			
32	99101-ZH80600	MAIN JET #60	1			
33	99204-ZE00350	PILOT JET SET #35	1			

GX120U1 (for Mikasa)

AIR CLEANER(1)

E-15

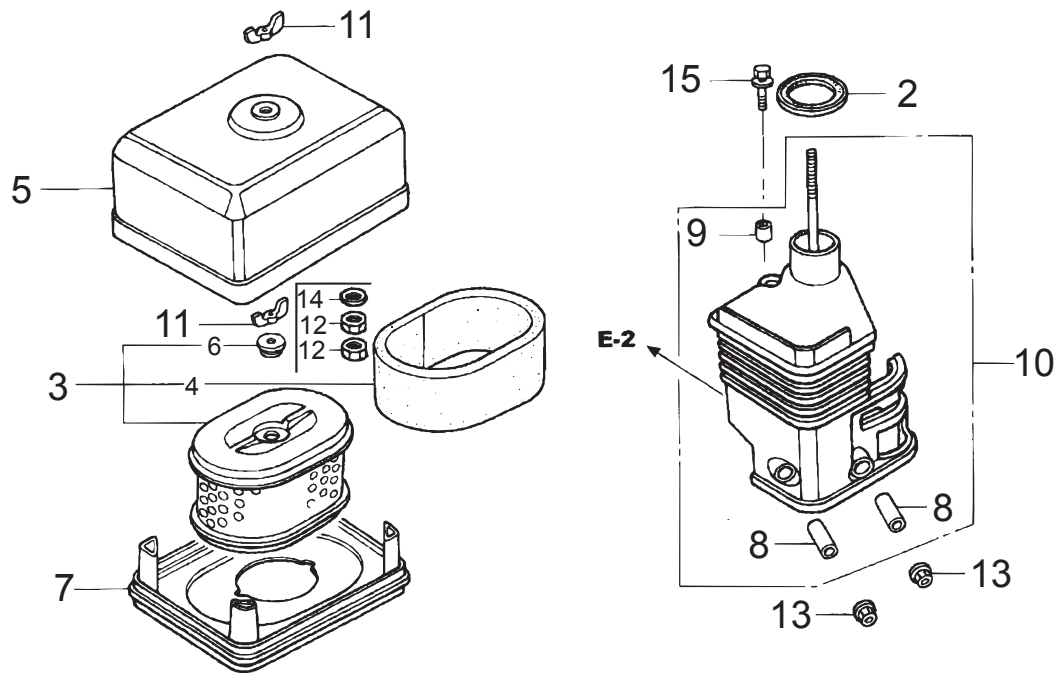

Z4F0-E1500 M



GX120U1-SM12 :for MQ MVH-R60H/HW, MVC-64H/HW
 GX120U1-SM14 :for EU / EXPORT MVH-R60, MVC-F60H/62H
 GX120U1-QMX2 :for MQ (INCHI) MVC-60H

2010/4/30

** APO **

REF NO.	PART NO.	PART NAME	Q' TY	MRK	MK2	REMARKS
2	16271-ZE1-000	PACKING, ELBOW	1			
3	17210-ZE0-505	ELEMENT SET	1			
4	17218-ZE0-505	OUTER ELEMENT	1			
5	17230-ZE0-820	COVER AIR CLEANER	1			
6	17232-891-000	GROMET, AIR CLEANER	1			
7	17235-ZE1-831	NOSE, SILENCER	1			
8	17238-ZE0-010	COLLAR, AIR CLEANER	2			
9	17239-ZE1-000	COLLAR(B), AIR CLEANER	1			
10	17410-ZE0-030	ELBOW COMP., AIR CLEANER	1			
11	90325-044-000	NUT	2			
13	94050-06000	FLANGE NUT 6MM	2			
15	95701-0602000	FLANGE BOLT 6X20	1			

GX120U1 (for Mikasa)

MUFFLER(1)

E-16

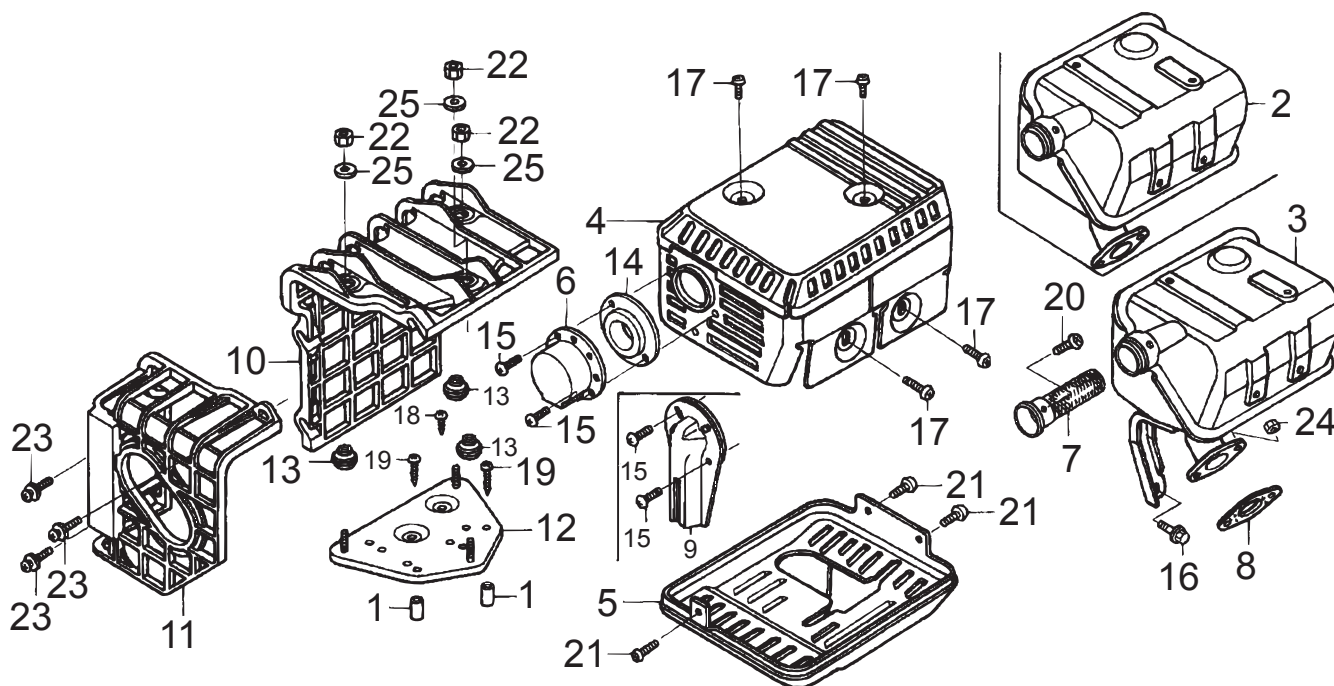

Z4F0-E1600 M



GX120U1-SM12 :for MQ MVH-R60H/HW, MVC-64H/HW
 GX120U1-SM14 :for EU / EXPORT MVH-R60, MVC-F60H/62H
 GX120U1-QMX2 :for MQ (INCHI) MVC-60H

2010/4/30

** APP **

REF NO.	PART NO.	PART NAME	Q' TY	MRK	MK2	REMARKS
2	18310-ZH8-810	MUFFLER COMP. (ARRESTER)	1			QMX2, SM12/14
3	18310-ZK8-V50	MUFFLER COMP. /GX120	1			SM12
3	18310-ZK8-V90	MUFFLER COMP. /GX120/SM14	1			SM14
4	18320-ZF1-H02	MUFFLER PROTECTOR (STD)	1			
6	18340-ZE1-010	DEFLECTOR CP	1			
7	18355-ZE1-000	ARRESTER, SPARK	1			QMX2, SM12/14
8	18381-ZH8-800	GASKET, MUFFLER	1		S!183	
14	18522-ZE1-000	GUIDE, MUFFLER	1			
15	90002-ZG0-003	TAPPING SCREW 4X8	2			
16	90016-ZE1-000	FLANGE BOLT 6X13	1			SM12, SM14
17	90050-ZE1-000	TAPPING SCREW 5X8	4			
20	90055-ZE1-000	TAPPING SCREW 4X6	1			QMX2, SM12/14
24	94001-080000S	NUT 8MM	2			

GX120U1 (for Mikasa)

FUEL TANK(1)

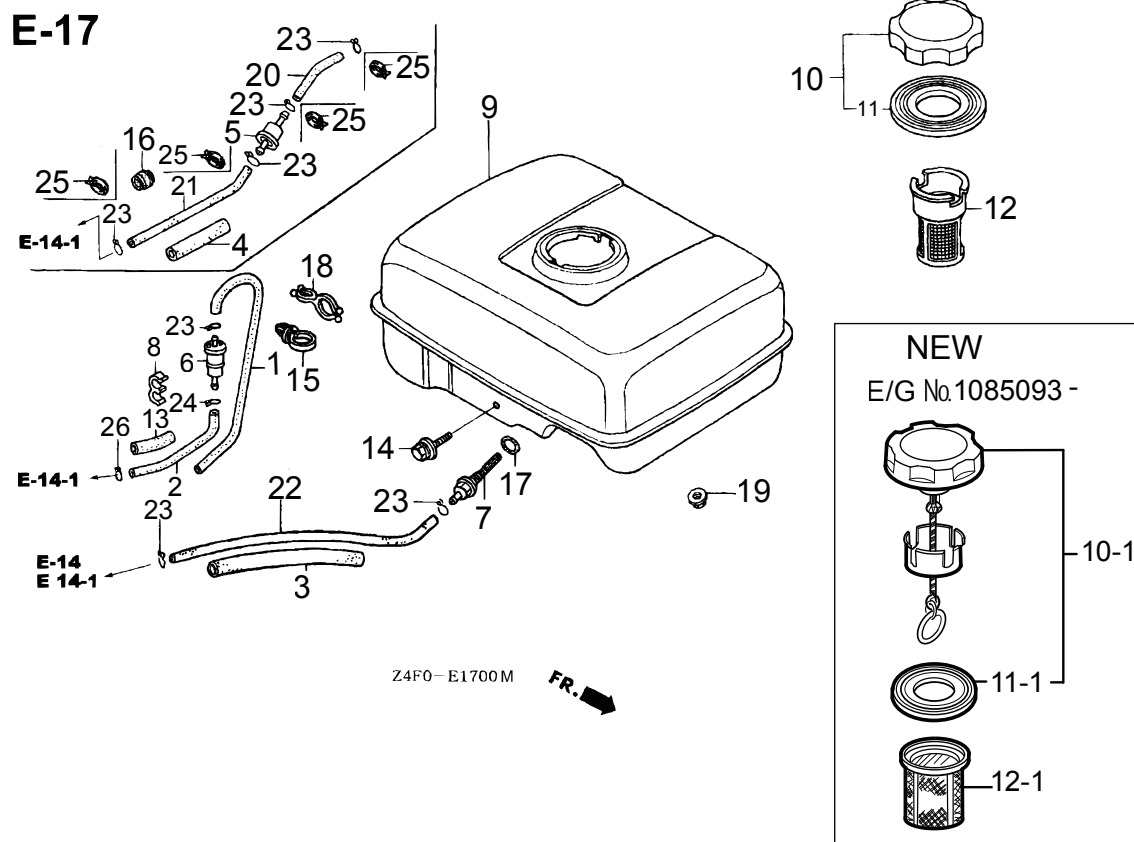

GX120U1-SM12 :for MQ MVH-R60H/HW, MVC-64H/HW
 GX120U1-SM14 :for EU / EXPORT MVH-R60, MVC-F60H/62H
 GX120U1-QMX2 :for MQ (INCHI) MVC-60H

2010/4/30

**** APQ ****

REF NO.	PART NO.	PART NAME	Q' TY	MRK	MK2	REMARKS
3	16854-ZH8-000	RUBBER, SUPPORT (107MM)	1			
7	16955-ZE1-000	JOINT, FUEL TANK	1			
9	17510ZE0020ZA	FUEL TANK CP GX120(W)	1			QMX2
9	17510ZE0020ZD	FUEL TANK CP GX120(B)	1			SM12, SM14
10	17620-Z0T-305	FUEL TANK CAP CP.	1			
10 -1	17620-Z4H-020	CAP COMP. , FUEL FILLER	1	XX		
11	17631-Z0T-812	PAKING, FUEL FILLER CAP	1			
11 -1	17631-Z0T-801	PACKING, FUEL FILLER CAP	1	XX		1085093-
11 -2	17631-Z4H-800	PACKING, FUEL FILLER CAP	1	XX		1143464-
11 -3	17631-Z0T-801	PACKING, FUEL FILLER CAP	1	XX		1150471-
12	17672-ZE2-W01	FUEL FILTER	1			
12 -1	17672-Z4H-000	FILTER, FUEL	1	XX		1085093-
14	90004-ZH7-003	FLANGE BOLT 6X29	1			
17	91353-671-004	O-RING 14MM	1			
19	94050-06000	FLANGE NUT 6MM	2			
22	950014500160M	FUEL TUBE 4.5X1M	1			
22	95001-45001		1	NC		
23	95002-02080	CLIP, TUBE	2			

GX120U1 (for Mikasa)

FLYWHEEL

E-19

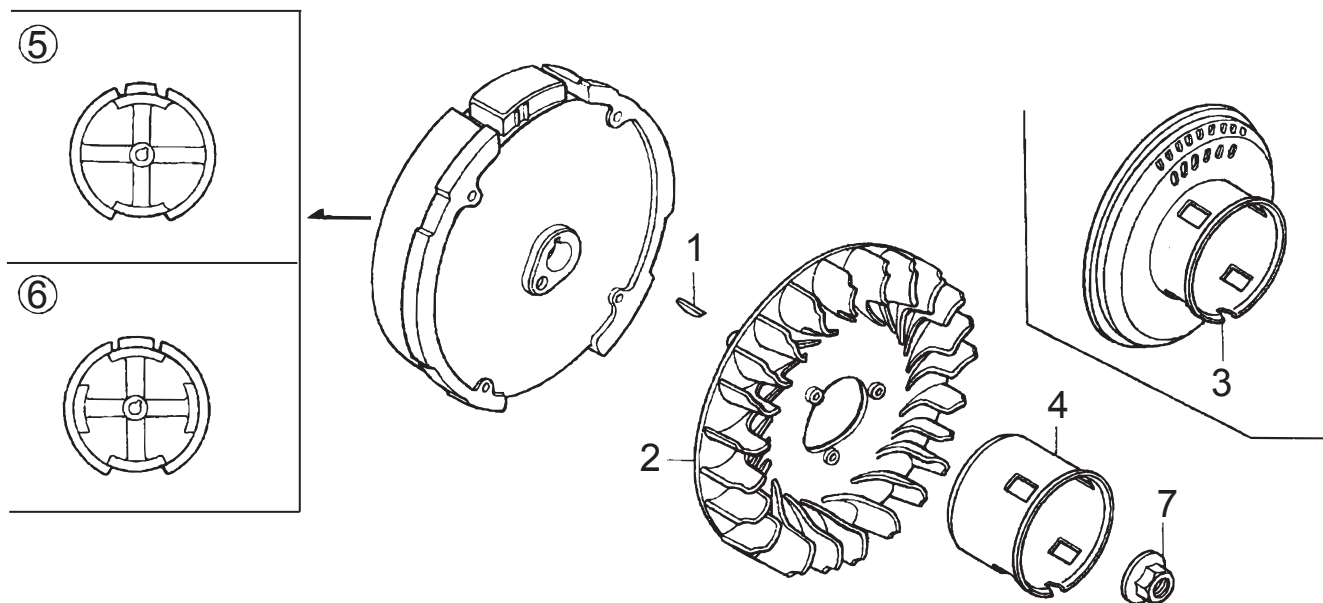

FR. →
Z4F0-E1900M

GX120U1-SM12 :for MQ MVH-R60H/HW, MVC-64H/HW
 GX120U1-SM14 :for EU / EXPORT MVH-R60, MVC-F60H/62H
 GX120U1-QMX2 :for MQ (INCHI) MVC-60H

2010/4/30

** APR **

REF NO.	PART NO.	PART NAME	Q' TY	MRK	MK2	REMARKS
1	13331-357-000	WOODRUFF KEY 25X18	1			
2	19511-ZE0-000	COOLING FAN	1			
4	28451-ZH7-801	STARTER PULLEY /GX120	1			
5	31100-ZE0-010	FLYWHEEL COMP.	1			
7	90201-878-003	SPECIAL NUT 14MM	1			

GX120U1 (for Mikasa)

IGNITION COIL

E-20

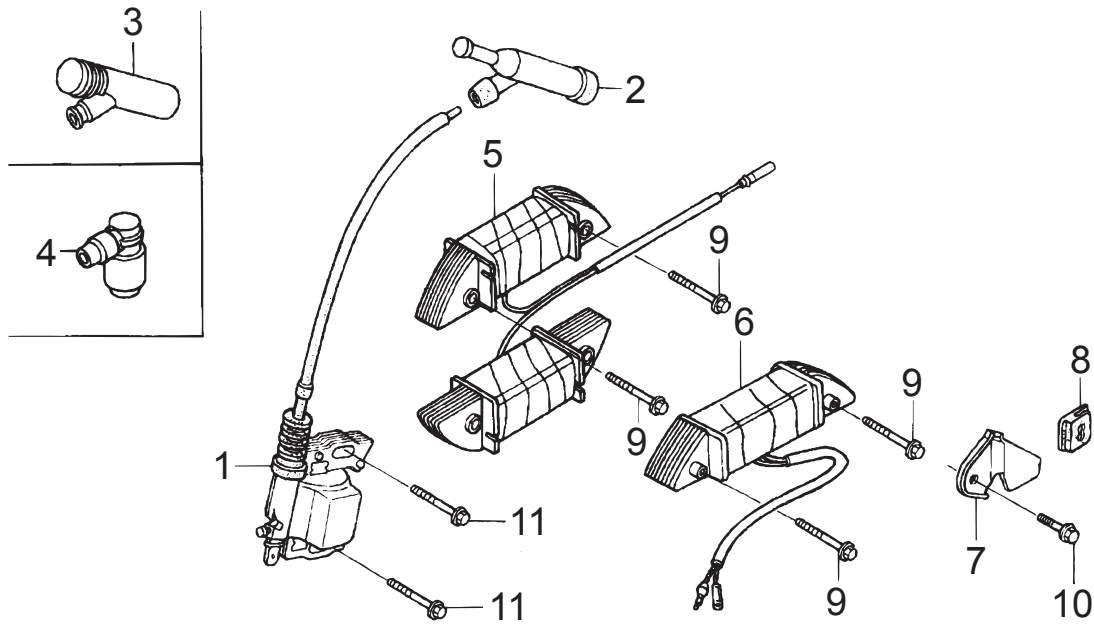

Z4F0-E2000M



GX120U1-SM12 :for MQ MVH-R60H/HW, MVC-64H/HW
 GX120U1-SM14 :for EU / EXPORT MVH-R60, MVC-F60H/62H
 GX120U1-QMX2 :for MQ (INCHI) MVC-60H

2010/4/30

**** APS ****

REF NO.	PART NO.	PART NAME	Q' TY	MRK	MK2	REMARKS
1	30500-ZE1-073	IGNITION COIL CP/GX160	1			
2	30700-ZE1-013	CAP ASSY.	1			
11	90121-952-000	FLANGE BOLT 6X25	2			

E-22

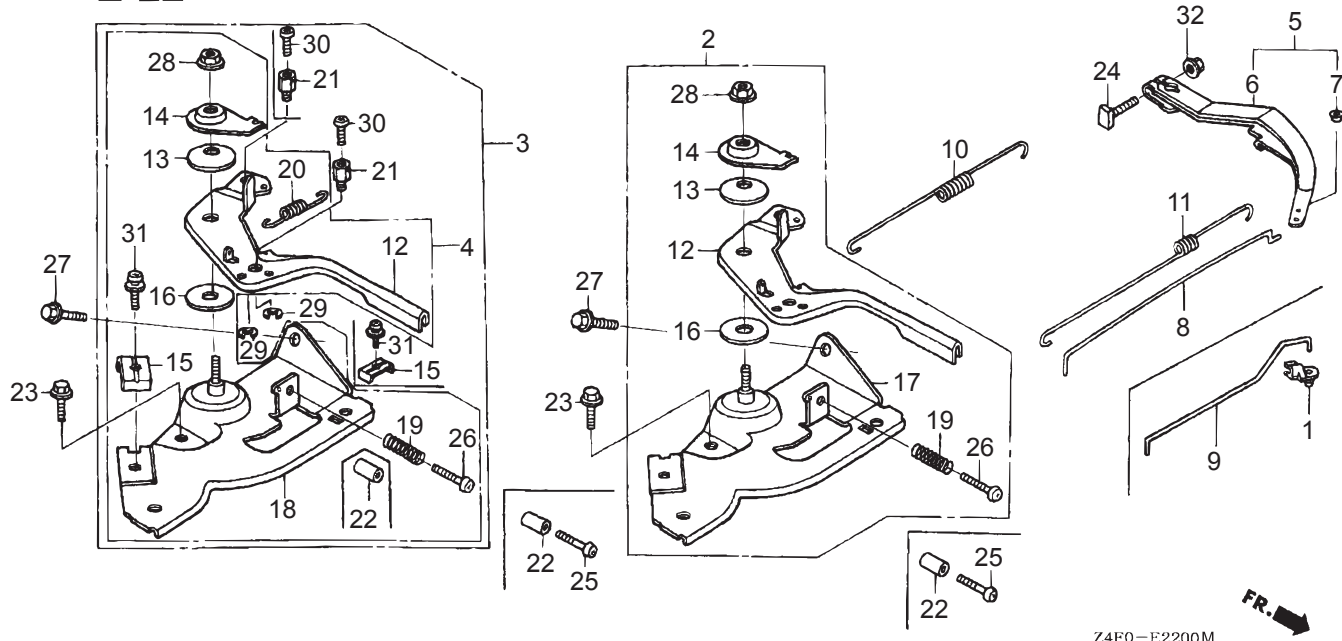

GX120U1-SM12 :for MQ MVH-R60H/HW, MVC-64H/HW
 GX120U1-SM14 :for EU / EXPORT MVH-R60, MVC-F60H/62H
 GX120U1-QMX2 :for MQ (INCHI) MVC-60H

2010/4/30

** APT **

REF NO.	PART NO.	PART NAME	Q' TY	MRK	MK2	REMARKS
3	16500-ZK7-U50	CONTROL ASSY.	1			SM12, SM14
3	16500-ZH7-810	CONTROL ASSY.	1			QMX2
6	16551-ZE0-010	GOVERNOR ARM	1			
8	16555-ZE0-000	GOVERNOR ROD	1			
10	16561-ZE0-020	GOVERNOR SPRING	1			
11	16562-ZE0-020	SPRING, THROTTLE	1			
12	16571-ZH7-000	LEVER, CONTROL	1			
13	16574-ZE1-000	LEVER SPRING	1			
14	16575-ZH8-000	WASHER, CONTROL LEVER	1			
15	16576-891-000	HOLDER, CABLE	2			SM12, SM14
15	16576-891-000	HOLDER, CABLE	1			QMX2
16	16578-ZE1-000	SPACER, CONTROL LEVER	1			
18	16580-ZH7-810	CONTROL BASE COMP.	1			
19	16584-883-300	ADJUSTING SPRING	1			
20	16592-ZE1-810	SPRING, CABLE, RETURN	1			
21	16594-883-010	HOLDER, WIRE	2			SM12, SM14
21	16594-883-010	HOLDER, WIRE	1			QMX2
23	90013-883-000	FLANGE BOLT 6X12	1			
24	90015-ZE5-010	BOLT, GOVERNOR ARM	1			
26	93500-050250H	SCREW 5X25	1			
27	90022-888-010	FLANGE BOLT 6X20	1			
28	90114-SA0-000	LOCK NUT 6MM	1			
29	90605-230-000	CIR CLIP	2			SM12, SM14
29	90605-230-000	CIR CLIP	1			QMX2
30	93500-040060H	SCREW 4X6	2			SM12, SM14
30	93500-040060H	SCREW 4X6	1			QMX2
31	93500-050160A	SCREW 5X16	2			SM12, SM14
31	93500-050160A	SCREW 5X16	1			QMX2
32	94050-06000	FLANGE NUT 6MM	1			

GX120U1 (for Mikasa)

LABEL

E-28

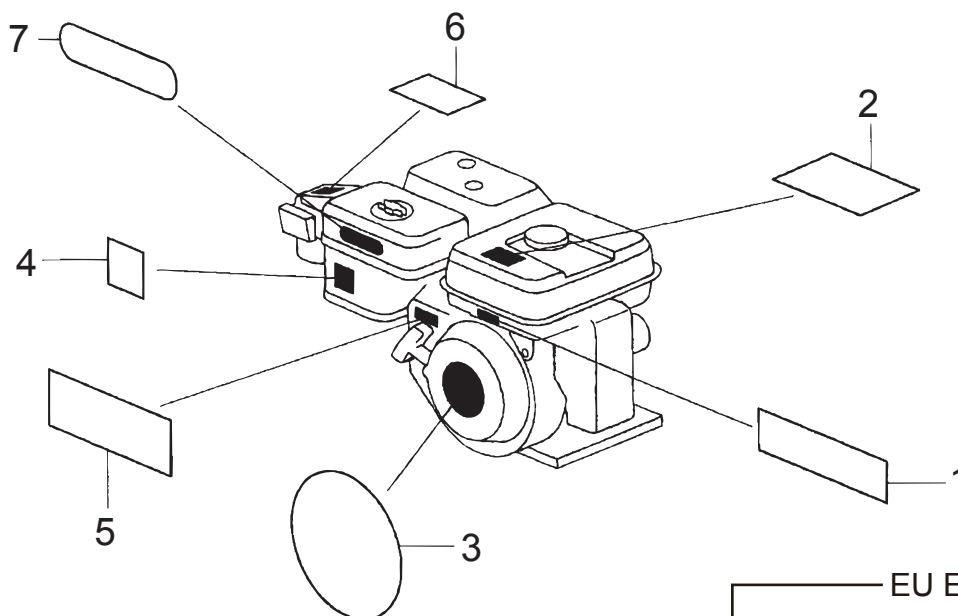

Z4F0-E2800M

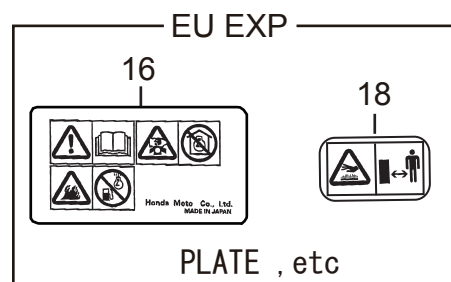

GX120U1-SM12 :for MQ MVH-R60H/HW, MVC-64H/HW
 GX120U1-SM14 :for EU / EXPORT MVH-R60, MVC-F60H/62H
 GX120U1-QMX2 :for MQ (INCHI) MVC-60H

2010/4/30

** APU **

REF NO.	PART NO.	PART NAME	Q' TY	MRK	MK2	REMARKS
2	87516-ZH7-000	MARK, OPERATOR CAUTION/EN	1			
2	87516-ZH7-810	MARK, OPERATOR CAUTION/GRA	1			
3	87521-ZH7-040	LABEL, TRADE MARK/GX120	1			
4	87528-ZH7-000	MARK, CHOKE (GRAY)/GX-U	1			
5	87532-ZH7-000	MARK, THROTTLE INDICATION	1			
16	87519-ZH7-000	MARK, OPE. CAUTION/PICTO	1		TO	EU/EXP
18	87539-Z0J-800	MARK, EX. CAUTION/PICTO	1			EU/EXP

GX120U1 (for Mikasa)

E-29

TOOL

APV

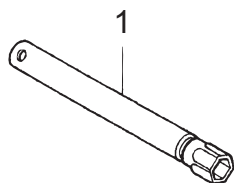

Z4F0-E2900M

Ref. No.	Part No.	Part Name	Qty	MRK	MK2	Remarks
1	89218-ZE1-000	WRENCH COMP., SPARK PLUG	1			

E-40

OTHER PARTS(1)

APW

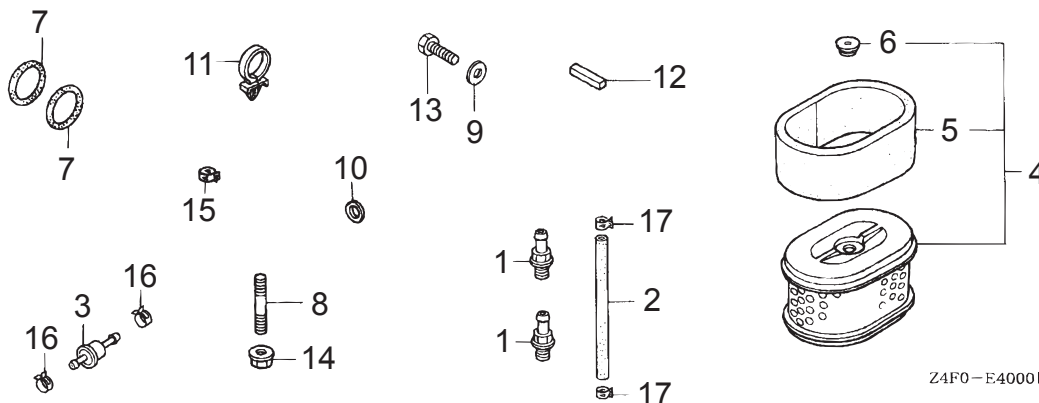

Z4F0-E4000M

Ref. No.	Part No.	Part Name	Qty	MRK	MK2	Remarks
1	15550-ZK8-P90	JOINT, DRAIN	2			SM12,SM14
2	15552-ZB9-000	TUBE, DRAIN	1			SM12,SM14
10	90601-ZE1-000	WASHER, DRAIN PLUG, 10.2MM	3			SM12,SM14
17	95002-4120008	CLAMP, TUBE (D12)	2			SM12,SM14

E-40-3

OTHER PARTS(4)

APX

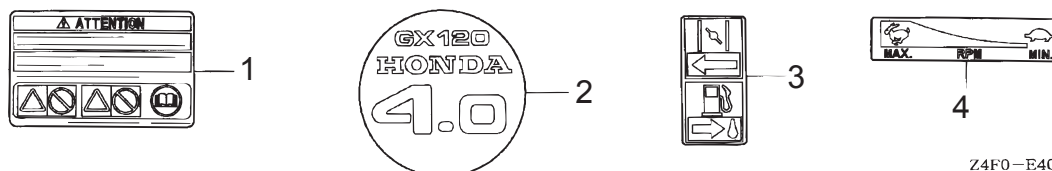

Z4F0-E4003M

Ref. No.	Part No.	Part Name	Qty	MRK	MK2	Remarks
1	87516-ZH7-800	MARK, OPERATOR CAUTION(FRENCH) (MADE IN	1			

GX120U1-SM12 :for MQ MVH-R60H/HW, MVC-64H/HW
 GX120U1-SM14 :for EU / EXPORT MVH-R60, MVC-F60H/62H
 GX120U1-QMX2 :for MQ (INCHI) MVC-60H



MIKASA SANGYO CO.,LTD.

HEAD OFFICE
NO. 4-3. 1-CHOME, SARUGAKU-CHO, CHIYODA-KU
TOKYO, JAPAN