

# **PARTS MANUAL**

**Models**

**EX27  
ENGINE**

PUB-EP1679  
Rev. 09/08

# **Robin America, Inc.**

905 Telsler Road • Lake Zurich, IL 60047 • Phone: 630-350-8200 • Fax: 630-350-8212  
e-mail: [sales@robinamerica.com](mailto:sales@robinamerica.com) • [www.subarupower.com](http://www.subarupower.com)

© Copyright 2008 Robin America, Inc.

## HOW TO USE THIS MANUAL

Robin engines are identified by MODEL, SPECIFICATION, and CODE NUMBER. For each model there may be many different versions called specifications. Each specification will be unique in some way. The difference may only be the paint color or it may have a different type of PTO or some other significant difference.

In order to identify the correct service part number, it is important to confirm the specification and code numbers for your engine. The specification and code number together are known as the PRODUCT NUMBER.

All Robin 4 cycle engines have a Product Number label similar to the label illustrated below.

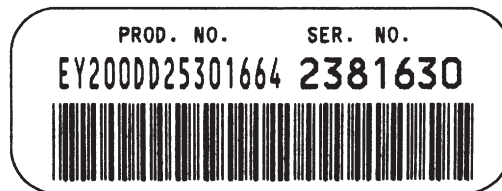
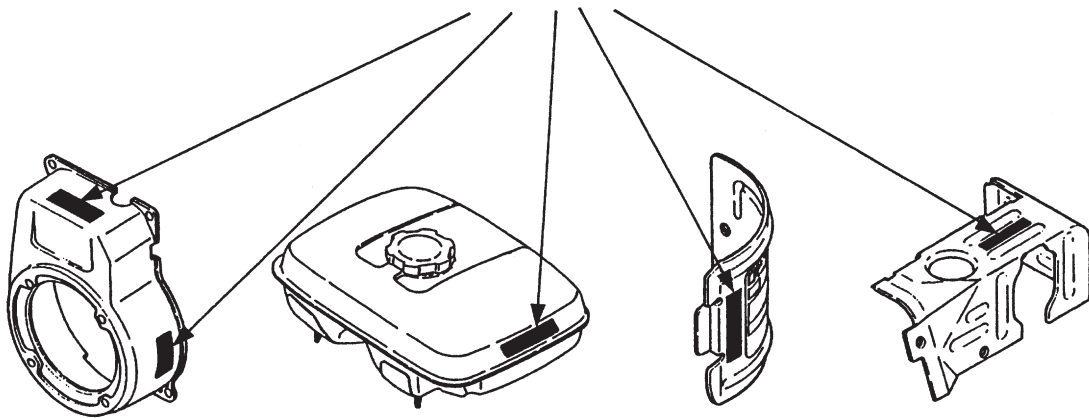

The Product Number Label has a 15 digit alphanumeric string that consists of the SPECIFICATION (SPEC) number (11 digits) and the CODE number (4 digits). Please note the illustration below:

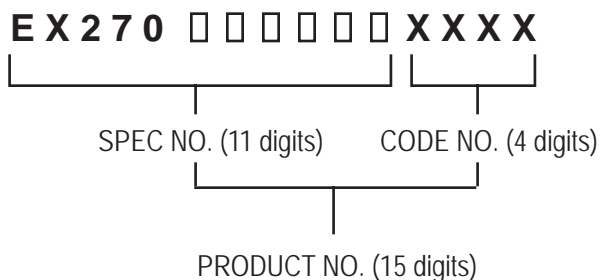

# MANUAL LAYOUT

1— SECTION 6 FUEL GROUP

2— FIG. 600

3

4

5

6

7

8

9

10

15

20,27

30

31

40

50

DETAIL A

1— SECTION 6 FUEL GROUP

REF.	PART NO.	DESCRIPTION	QTY.	REMARKS	FROM-TO	FIG.
10	267-60103-01	FUEL TANK CP	1	YD. YS TYPE, BLACK		600
27	267-60101-01	FUEL TANK CP	1	YELLOW		600
30	043-04300-15	FUEL TANK CAP CP	1	YD. YS TYPE		600
31	267-95201-03	LABEL, WARNING	1	YD. YS TYPE		600
40	064-13600-10	FUEL FILTER	1			600
50	064-20021-01	FUEL STRAINER, AY	1			600
-1	064-20002-20	FILTER	1			600
-2	064-20002-30	GASKET	1			600
-3	064-20019-10	CLIP	1			600

1. SECTION NAME Parts are broadly classified according to their functions. Refer to the Group Index (table of contents) for respective section name.
2. FIG. No. The FIG. number indexes the reference and part numbers to the illustration. Figure numbers that vary only in the tens place (i.e.: 700 and 710) are in a group of the same section (i.e.: Electrical Device Group).
3. REF. No. The Reference number identifies the part illustration with the corresponding part number in the part list.
4. SUBASSEMBLY SUBASSEMBLY parts of part assembly are listed below the assembly part. The subassembly part reference number is indicated by the number led by "-" such as "-1", "-2".
5. PART NUMBER It is the number assigned for sales unit. Use the PART No. when making an order.
6. DESCRIPTION It is designation of the part.
7. QTY. Quantity of each part used for each product.
8. REMARKS This gives a distinctive feature and/or a supplementary comment for the type, the specification, and the part concerned. It also shows part number(s) interchangeable for the part.
9. FROM-TO This section shows the CODE No. to indicate the history of progress in which improved parts have been introduced in the product. The FROM-TO CODE No. helps to identify PART No. being employed in the product concerned. See the examples below:
  - The part is used in the product irrespective of CODE No.
  - 2101- The part is used in the products with CODE No. of 2101 and after this number.
  - 2100 The part is used in the products with CODE No. of 2100 and before this number.

# GROUP INDEX

Group Name	Page
CRANKCASE GROUP .....	6
CRANKSHAFT GROUP .....	8
INTAKE and EXHAUST GROUP .....	10
GOVERNOR GROUP .....	14
COOLING and STARTING GROUP .....	16
FUEL, LUBRICANT GROUP .....	18
CARBURETOR GROUP .....	26
ELECTRIC DEVICE GROUP .....	38
ACCESSORY GROUP .....	42

INDEX OF DESCRIPTION SYMBOLS			
SYMBOL	DESCRIPTION	SYMBOL	DESCRIPTION
AY .....	ASSEMBLY	P= .....	PITCH (in mm)
CP .....	COMPLETE	P.T.O. (PTO) .....	POWER TAKE OFF
EX .....	EXPORT (from Japan)	REF .....	REFERENCE
FIG .....	FIGURE	R.H. (RH) .....	RIGHT HAND SIDE
FR .....	FRONT	RR .....	REAR
" .....	INCH	STD. ....	STANDARD
INCL. ....	INCLUDE	SW .....	SWITCH
-L .....	LITER	T= .....	THICKNESS (in mm)
L= .....	LENGTH (in. mm)	UN .....	UNIT
L.H. (LH) .....	LEFT-HAND SIDE	U.S. ....	UNDER SIZE
MECH .....	MECHANICAL	~V .....	VOLTAGE
NO (NON) .....	NONE	~W .....	WATT
OPT .....	OPTIONAL	W/ .....	WITH
O.S. ....	OVER SIZE	W/O .....	WITHOUT

SECTION 1 CRANKCASE GROUP

FIG. 100

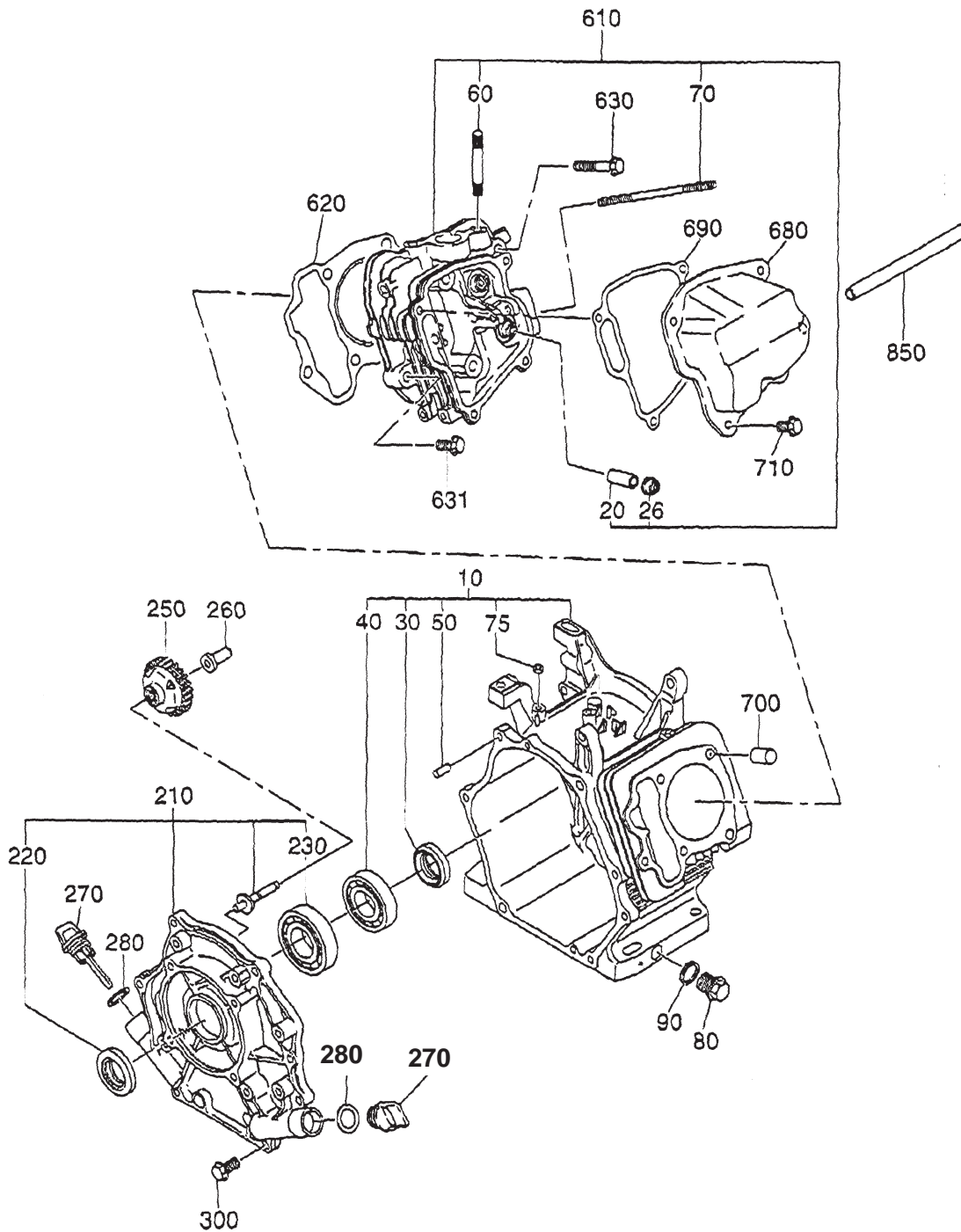

# SECTION 1 CRANKCASE GROUP

REF.	PART NO.	DESCRIPTION	QTY.	REMARKS	FROM-TO	FIG.
10	279-10101-91	Crankcase Cp	1	Std	6951~	100
	279-10101-81	Crankcase Cp	1		~6950	100
10	279-10102-91	Crankcase Cp	1	w/ oil sensor	6951~	100
	279-10102-81	Crankcase Cp	1	w/ oil sensor	~6950	100
10	279-10104-51	Crankcase Cp	1	Balancer Shaft	7092~	100
	279-10104-41	Crankcase Cp	1		6951~7901	100
	279-10104-31	Crankcase Cp	1		~6950	100
20	237-14202-03	Valve Guide	2			100
26	277-16010-01	Stem Seal	1			100
30	044-03001-60	Oil Seal	1			100
40	060-03003-41	Ball Bearing	1			100
46	060-01500-11	Ball Bearing	1		7092~	100
	060-01500-10	Ball Bearing	1		~7091	100
50	277-15011-03	Pipe Knock	2			100
60	010-50802-50	Stud	2	Exhaust		100
70	010-50604-10	Stud	2	Intake		100
75	044-00600-20	Oil Seal	1			100
80	040-11400-30	Plug	1			100
90	021-11400-20	Gasket	1			100
210	279-11002-11	Main Bearing Cover Cp	1	Std		100
210	279-11004-11	Main Bearing Cover Cp	1	Balancer Shaft		100
220	044-03001-60	Oil Seal	1			100
230	060-03003-70	Ball Bearing	1			100
235	060-01500-11	Ball Bearing	1		7092~	100
	060-01500-10	Ball Bearing	1		~7091	100
250	277-45004-J1	Governor Gear Cp	1			100
260	277-41901-03	Governor Sleeve	1			100
270	279-63601-13	Oil Gauge	2			100
280	021-32000-50	Gasket	1			100
300	001-04083-50	Flange Bolt	7			100
610	279-13001-21	Cylinder Head Cp	1			100
620	279-15001-33	Gasket, head	1			100
630	011-00802-40	Flange Bolt	4			100
631	011-00803-10	Flange Bolt	1			100
680	277-15503-01	Rocker Cover Cp	1			100
690	277-16001-13	Gasket, rocker cover	1			100
700	277-15011-03	Pipe Knock	2			100
710	011-00600-20	Flange Bolt	4			100
960	279-99001-27	Gasket Set	1			100

SECTION 2 CRANKSHAFT GROUP

FIG. 200

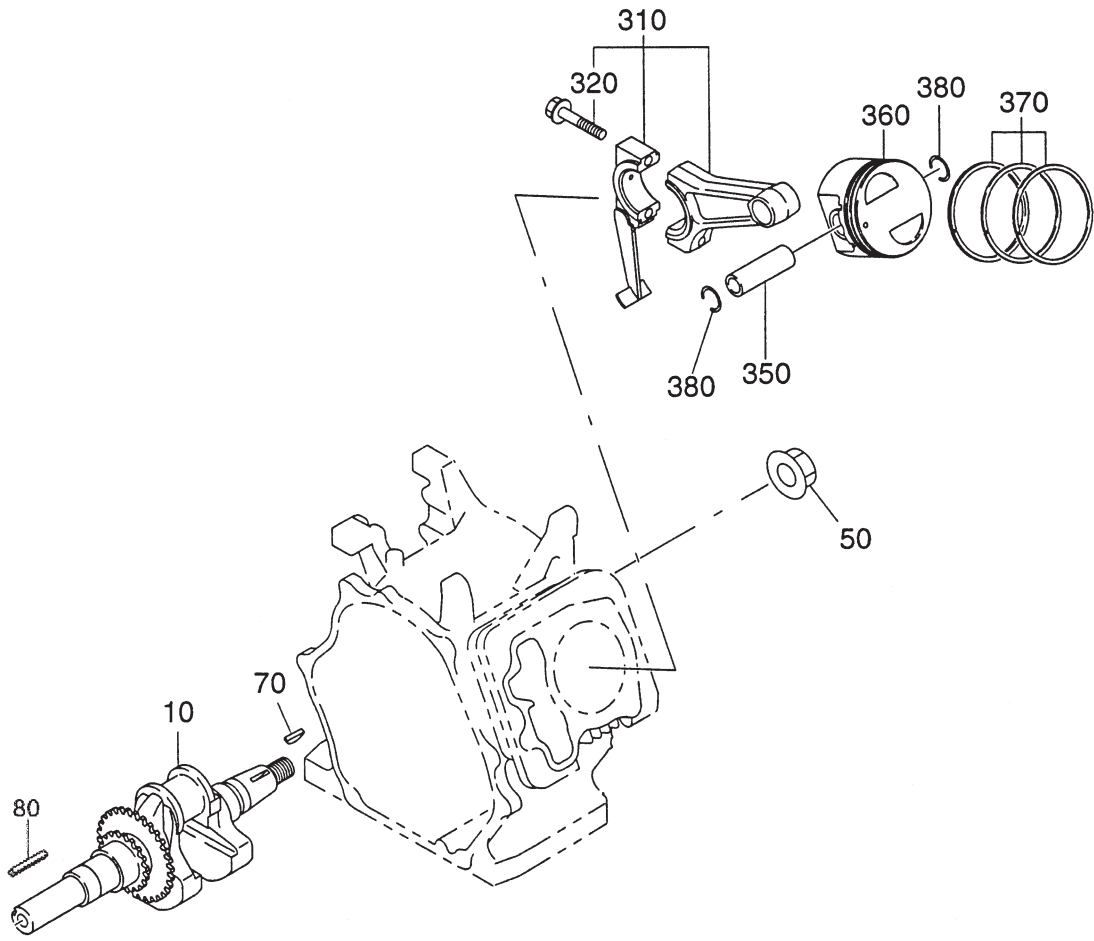





SECTION 3 INTAKE and EXHAUST GROUP - NEW STYLE

FIG. 300

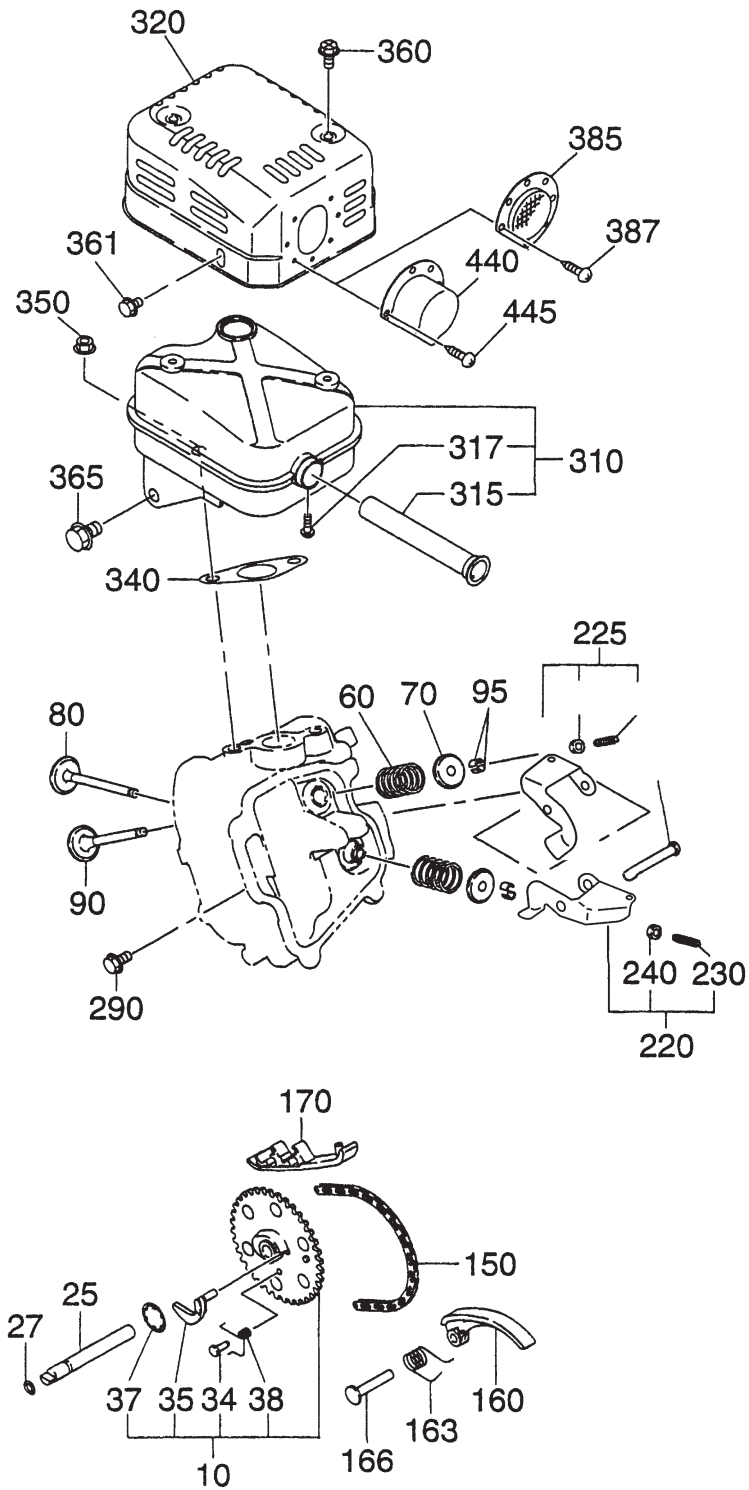

### SECTION 3 INTAKE and EXHAUST GROUP - NEW STYLE

REF.	PART NO.	DESCRIPTION	QTY.	REMARKS	FROM-TO	FIG.
10	279-31601-01	Camshaft Cp	1			300
25	277-35101-03	Pin, camshaft	1			300
27	024-00600-10	O ring	1			300
34	277-38601-03	Pin, spring	1			300
35	279-36401-03	Release Lever	1			300
37	277-36501-03	Clip	1			300
38	227-38701-03	Return Spring	1			300
60	279-33601-03	Valve Spring	2			300
70	269-33701-03	Spring Retainer	2			300
80	279-33401-H3	Intake Valve	1			300
90	279-33501-H3	Exhaust Valve	1			300
95	132-10KA0-31	Collet Valve	4			300
150	279-35601-11	Timing Chain	1	100 link		300
160	277-36911-03	Tentioner	1			300
163	277-37101-03	Spring, tentioner	1			300
166	277-36902-03	Pin, tentioner	1			300
170	277-36913-13	Chain Guide	1			300
200	277-35002-01	Pin, rocker cp	1			300
202	003-13050-00	Clip	1			300
220	277-36201-00	Rocker Arm Ay, intake	1			300
225	277-36202-00	Rocker Arm Ay, exhaust	1			300
230	014-90500-20	Adjust Screw	1			300
231	014-90500-20	Adjust Screw	1			300
240	017-00500-30	Nut	1			300
241	017-00500-30	Nut	1			300
290	011-00600-20	Flange Bolt	1			300
310	279-30101-L1	Muffler Cp	1		6972~	300
	279-30101-K1	Muffler Cp	1		~6971	300
310	279-30111-L1	Muffler Cp	1	DE		300
315	279-37601-01	Spark Arrestor Cp	1			300
317	015-00400-60	Tapping Screw	1			300
320	279-34201-21	Muffler Cover Cp	1		7031~	300
	279-34201-11	Muffler Cover Cp	1		~7030	300
340	277-35201-13	Gasket, muffler	1			300
350	980-20082-80	Flange Nut	2			300
360	015-20600-90	Tapping Bolt	2			300
361	011-00600-10	Flange Bolt	1			300
365	011-00803-20	Flange Bolt	1			300
385	277-37203-H1	Screen	1			300
387	015-00400-60	Tapping Screw	2			300
440	277-37001-H1	Deflector Cp	1			300
540	279-32902-J1	Insulator Cp	1			300
560	279-35902-J3	Gasket 1, insulator	1			300
570	002-38060-00	Flange Nut	2			300
580	001-04062-00	Flange Bolt	1			300

FIG. 300

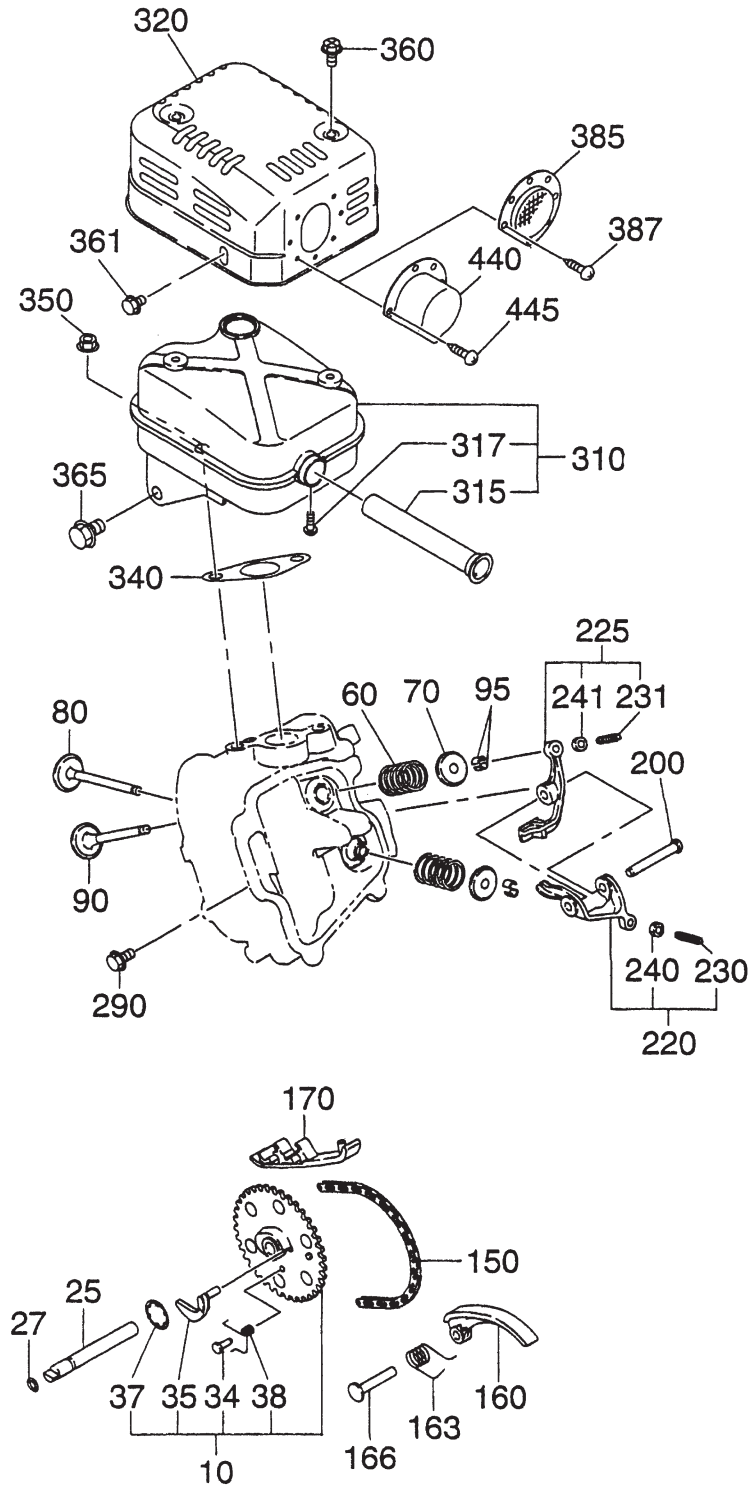

### SECTION 3 INTAKE and EXHAUST GROUP - OLD STYLE

REF.	PART NO.	DESCRIPTION	QTY.	REMARKS	FROM-TO	FIG.
10	279-31601-01	Camshaft Cp	1		~2099999	300
25	277-35101-03	Pin, camshaft	1		~2099999	300
27	024-00600-10	O ring	1		~2099999	300
34	277-38601-03	Pin, spring	1		~2099999	300
35	279-36401-03	Release Lever	1		~2099999	300
37	277-36501-03	Clip	1		~2099999	300
38	277-38701-03	Return Spring	1		~2099999	300
60	279-33601-03	Valve Spring	2		~2099999	300
70	269-33701-03	Retainer Valve Spring	2		~2099999	300
80	279-33401-13	Intake Valve	1		~2099999	300
90	279-33501-13	Exhaust Valve	1		~2099999	300
95	132-10KA0-31	Collet Valve	4		~2099999	300
150	279-35601-01	Timing Chain Cp	1		~2099999	300
160	277-36911-03	Tentioner	1		~2099999	300
163	277-37101-03	Spring, tentioner	1		~2099999	300
166	277-36902-03	PIN, tentioner	1		~2099999	300
170	277-36913-13	Chain Guide	1		~2099999	300
200	277-35001-23	Pin, rocker	1		~2099999	300
220	277-36101-00	Rocker Arm Ay, intake	1		~2099999	300
225	277-36102-00	Rocker Arm Ay, exhaust	1		~2099999	300
230	014-90500-10	Adjust Screw	1		~2099999	300
231	014-90500-10	Adjust Screw	1		~2099999	300
240	017-00500-20	Nut	1		~2099999	300
241	017-00500-20	Nut	1		~2099999	300
290	011-00600-20	Flange Bolt	1		~2099999	300
310	279-30101-21	Muffler Cp	1		~2099999	300
	279-30111-01	Muffler Cp	1	w/ spark arrestor	~2099999	300
315	279-37601-01	Spark Arrestor	1		~2099999	300
317	015-00400-60	Tapping Screw	1		~2099999	300
320	279-34201-11	Muffler Cover Cp	1		~2099999	300
340	277-35201-03	Gasket, muffler	1		~2099999	300
350	980-20082-80	Flange Nut	2		~2099999	300
360	015-20600-90	Tapping Bolt	2		~2099999	300
361	011-00600-10	Flang Bolt	1		~2099999	300
365	011-00801-50	Flange Bolt	1		~2099999	300
385	277-37203-01	Screen Cp	1		~2099999	300
387	015-00400-60	Tapping Screw	2		~2099999	300
440	277-37001-03	Deflector	1		~2099999	300
445	015-00400-60	Tapping Screw	2		~2099999	300
570	002-38060-00	Flange Nut	2		~2099999	300
580	011-00600-50	Flange Nut	1		~2099999	300

SECTION 3 INTAKE and EXHAUST GROUP

FIG. 310

**A** Foam

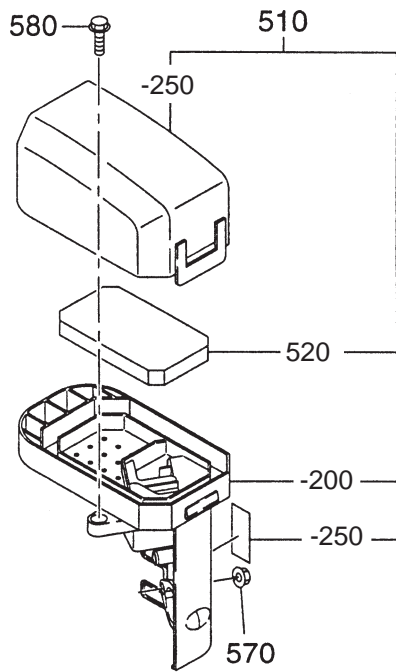

**B** Dual Element

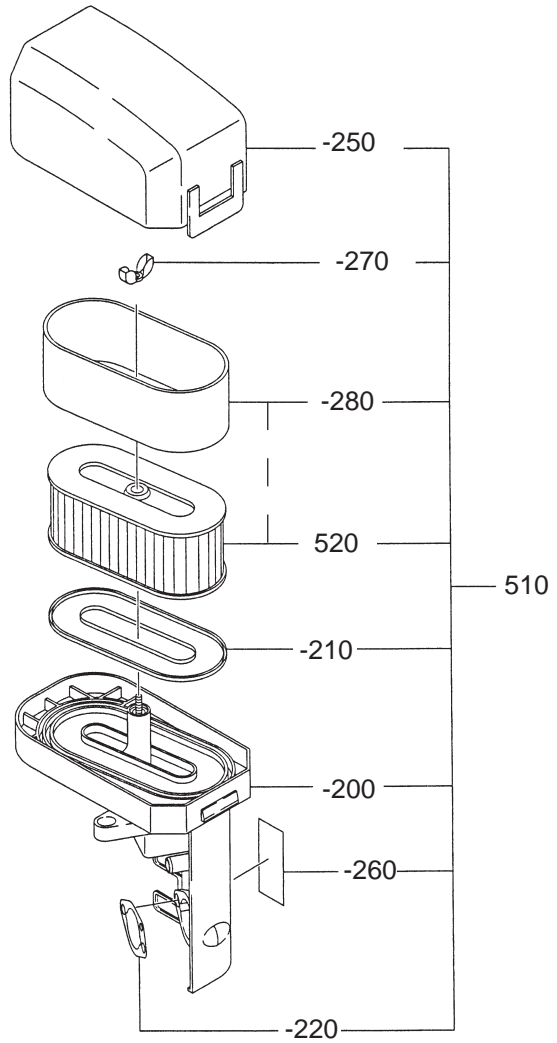



SECTION 3 INTAKE and EXHAUST GROUP

FIG. 320

**C** Cyclone Pre-cleaner

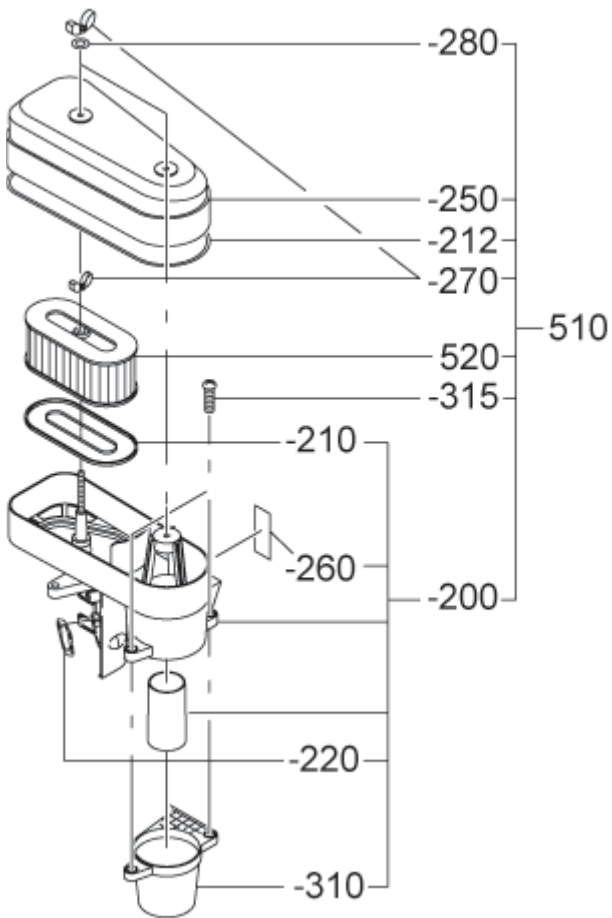

**D** Low Profile

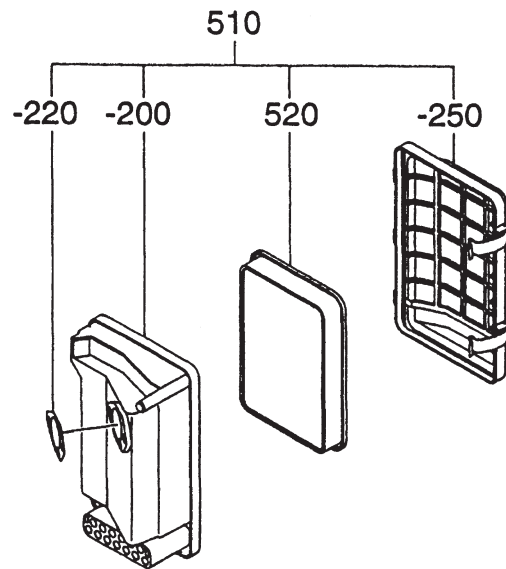



### SECTION 3 INTAKE and EXHAUST GROUP

REF.	PART NO.	DESCRIPTION	QTY.	REMARKS	FROM-TO	FIG.
510	279-32613-30	Air Cleaner Ay	1	Cyclone Pre-cleaner		315C
	279-32620-30	Air Cleaner Ay	1	Low Profile		315D
-200	279-32632-28	Elbow Cp	1	Cyclone Pre-cleaner		315C
	279-32633-08	Cleaner Body	1	Low Profile		315D
-210	279-32720-08	Packing	1			315
-212	279-32670-08	Seal	1	Cyclone Pre-cleaner		315C
-220	279-32650-08	Gasket	1			315
-250	279-32641-18	Cover	1	Cyclone Pre-cleaner		315C
	279-32644-08	Cover	1	Low Profile		315D
-254	279-32683-08	Clip	2	Low Profile		315D
-260	279-32730-08	Label	1			315
-270	279-32740-08	Nut	1	Cyclone Pre-cleaner		315C
-280	279-32675-08	Washer	1	Cyclone Pre-cleaner		315C
-310	279-32660-08	Dust Case	1	Cyclone Pre-cleaner		315C
-316	279-32680-08	Screw, pan	2	Cyclone Pre-cleaner		315C
-520	279-32607-07	Element Cp	1	Cyclone Pre-cleaner		315C

SECTION 4 GOVERNOR GROUP - NEW STYLE

FIG. 400

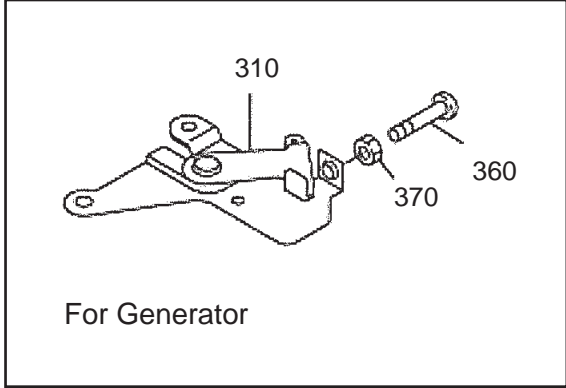
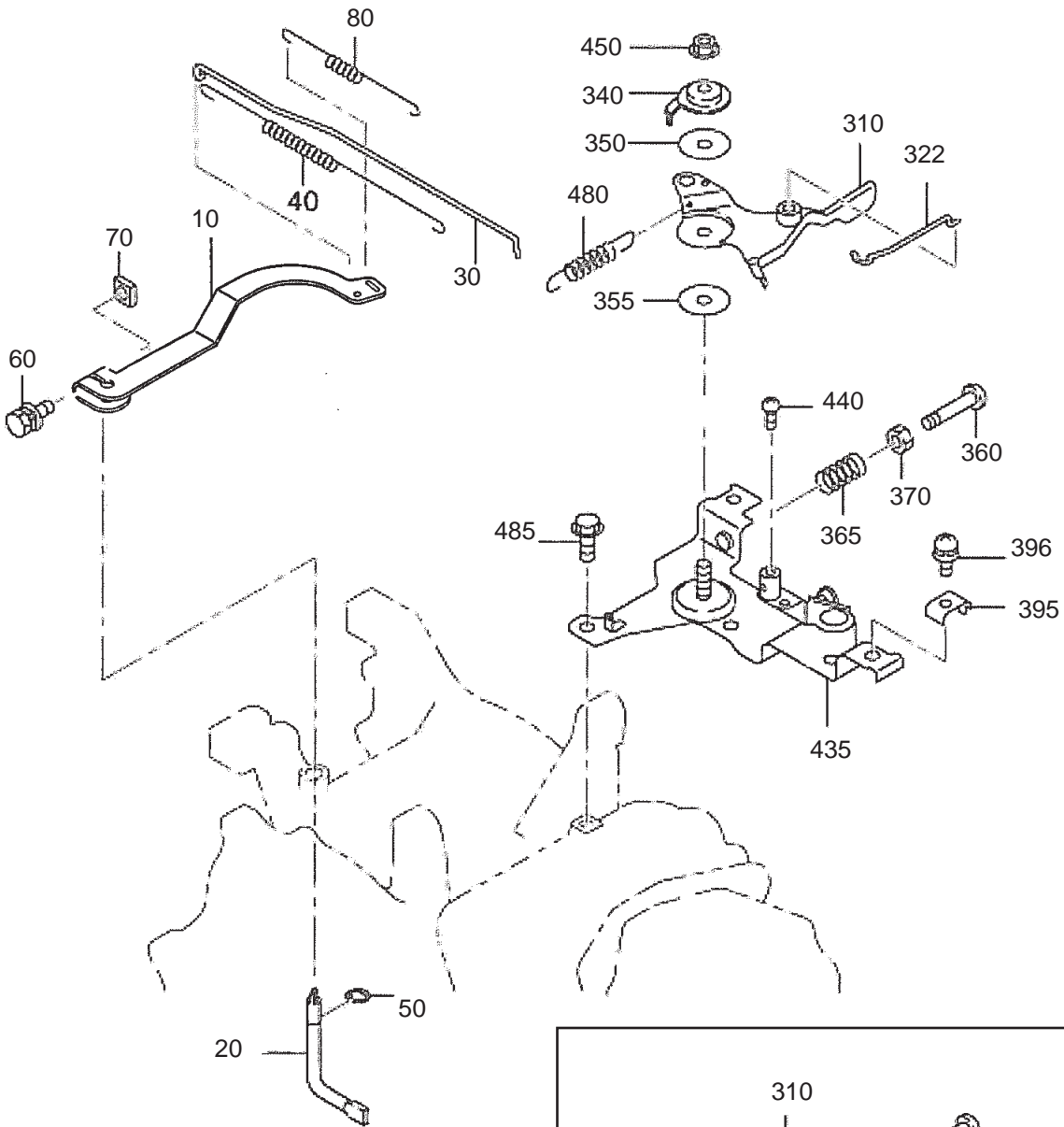

## SECTION 4 GOVERNOR GROUP - NEW STYLE

REF.	PART NO.	DESCRIPTION	QTY.	REMARKS	FROM-TO	FIG.
10	279-42301-53	Governor Lever	1		6998~	400
	279-42301-43	Governor Lever	1		~6997	400
20	277-42201-33	Governor Shaft	1			400
30	279-42701-11	Governor Rod Cp	1			400
40	277-42801-23	Rod Spring	1			400
50	003-13050-00	Clip	1			400
60	013-00602-40	Bolt and Washer Ay	1			400
70	018-60600-20	Nut	1			400
80	279-42502-63	Governor Spring	1			400
310	277-43303-01	Speed Control Lever Cp	1	Manual / Remote Type		400
	277-43303-03	Speed Control Lever Cp	1	Manual Type		400
	277-46501-11	Speed Control Lever Cp	1	Generator		400
322	277-43701-01	Link Rod Cp	1			400
340	277-43502-03	Stop Plate	1			400
350	277-44501-03	Washer	1			400
355	021-70600-70	Friction Washer	1			400
360	004-31062-50	Screw	1			400
	004-31064-00	Screw	1	Generator		400
365	237-45004-23	Spring, adjust	1			400
370	002-17060-00	Nut	1			400
395	277-43902-03	Clamp	1			400
396	013-10500-30	Screw and Washer Ay	1			400
435	277-46002-01	Speed Control Bracket	1	Manual / Remote Type		400
	277-46007-01	Speed Control Bracket	1	Pre-cleaner A/C Type		400
	277-46002-02	Speed Control Bracket	1	Manual Type		400
440	004-31040-80	Screw	1			400
450	002-35060-00	Self Lock Nut	1			400
480	277-45103-03	Return Spring	1			400
485	011-00600-20	Flange Bolt	2			400

SECTION 4 GOVERNOR GROUP - OLD STYLE

FIG. 400

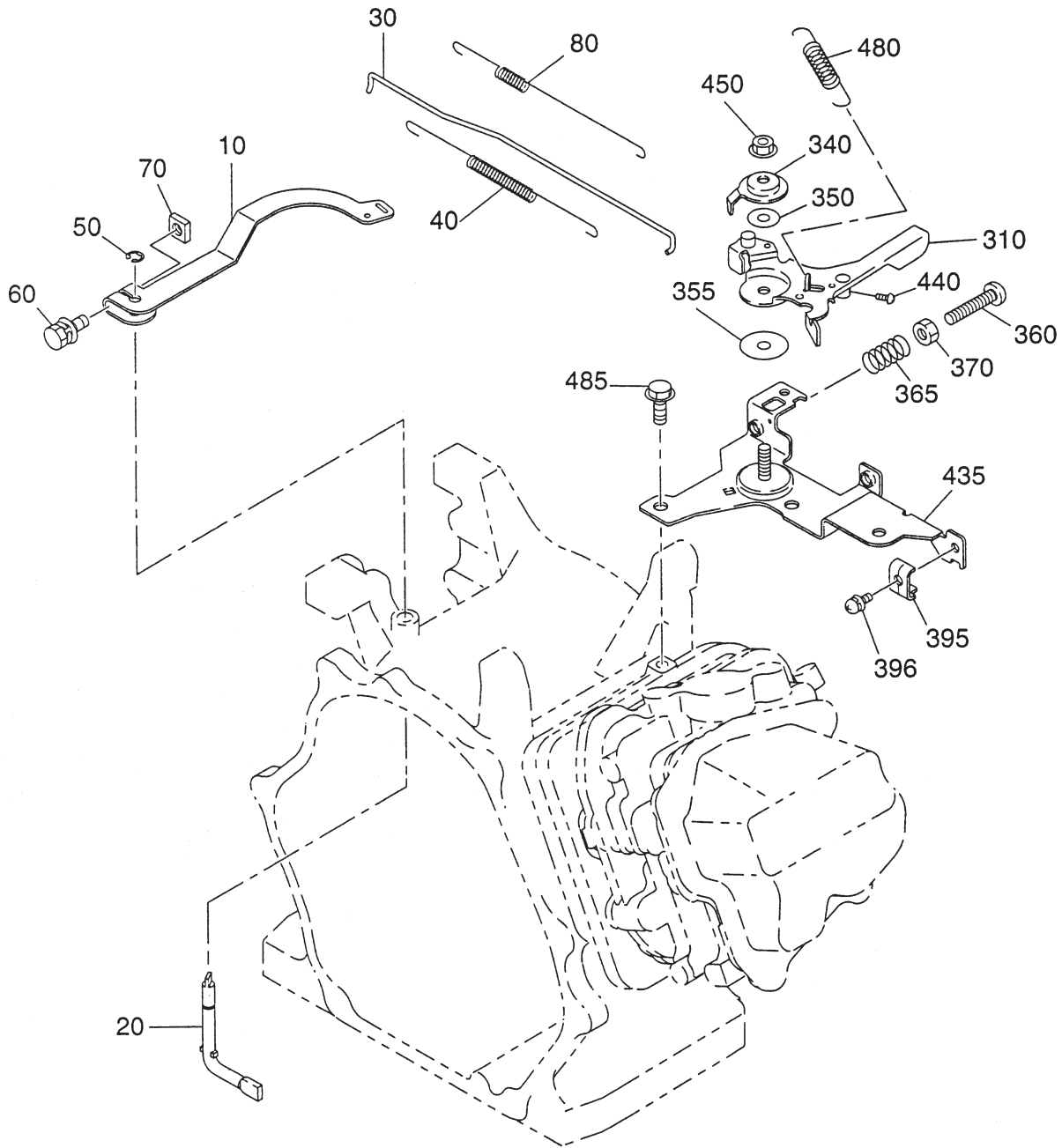

**SECTION 4 GOVERNOR GROUP - OLD STYLE**

REF.	PART NO.	DESCRIPTION	QTY.	REMARKS	FROM-TO	FIG.
10	279-42301-13	Governor Lever	1		~2099999	400
20	277-42201-33	Governor Shaft	1		~2099999	400
30	279-42701-01	Governor Rod Cp	1		~2099999	400
40	277-42801-13	Rod Spring	1		~2099999	400
50	003-13050-00	Clip	1		~2099999	400
60	001-14062-40	Bolt and Washer Ay	1		~2099999	400
70	018-60600-20	Nut	1		~2099999	400
80	279-42502-23	Governor Spring	1		~2099999	400
310	279-43302-01	Speed Lever Controller	1		~2099999	400
340	277-43501-03	Stop Plate	1		~2099999	400
350	020-00601-70	Washer	1		~2099999	400
355	021-70600-70	Friction Washer	1		~2099999	400
360	014-00601-80	Screw	1		~2099999	400
365	237-45004-23	Spring, adjust	1		~2099999	400
370	002-17060-00	Nut	1		~2099999	400
395	277-43901-03	Clamp	1		~2099999	400
396	004-36051-60	Screw and Washer Ay	1		~2099999	400
435	277-46001-01	Speed Control Brkt Cp	1		~2099999	400
440	004-31040-80	Screw	1		~2099999	400
450	002-35060-00	Self Lock Nut	1		~2099999	400
480	277-45101-03	Return Spring	1		~2099999	400
485	011-00600-20	Flange Bolt	2		~2099999	400
490	277-45002-10	SPEED Control Ay	1	Incl. the following items:	~2099999	
				310,340,350,355,360,365,395,		
				396,435,440,450,480,486		

SECTION 5 COOLING and STARTING GROUP

FIG. 500

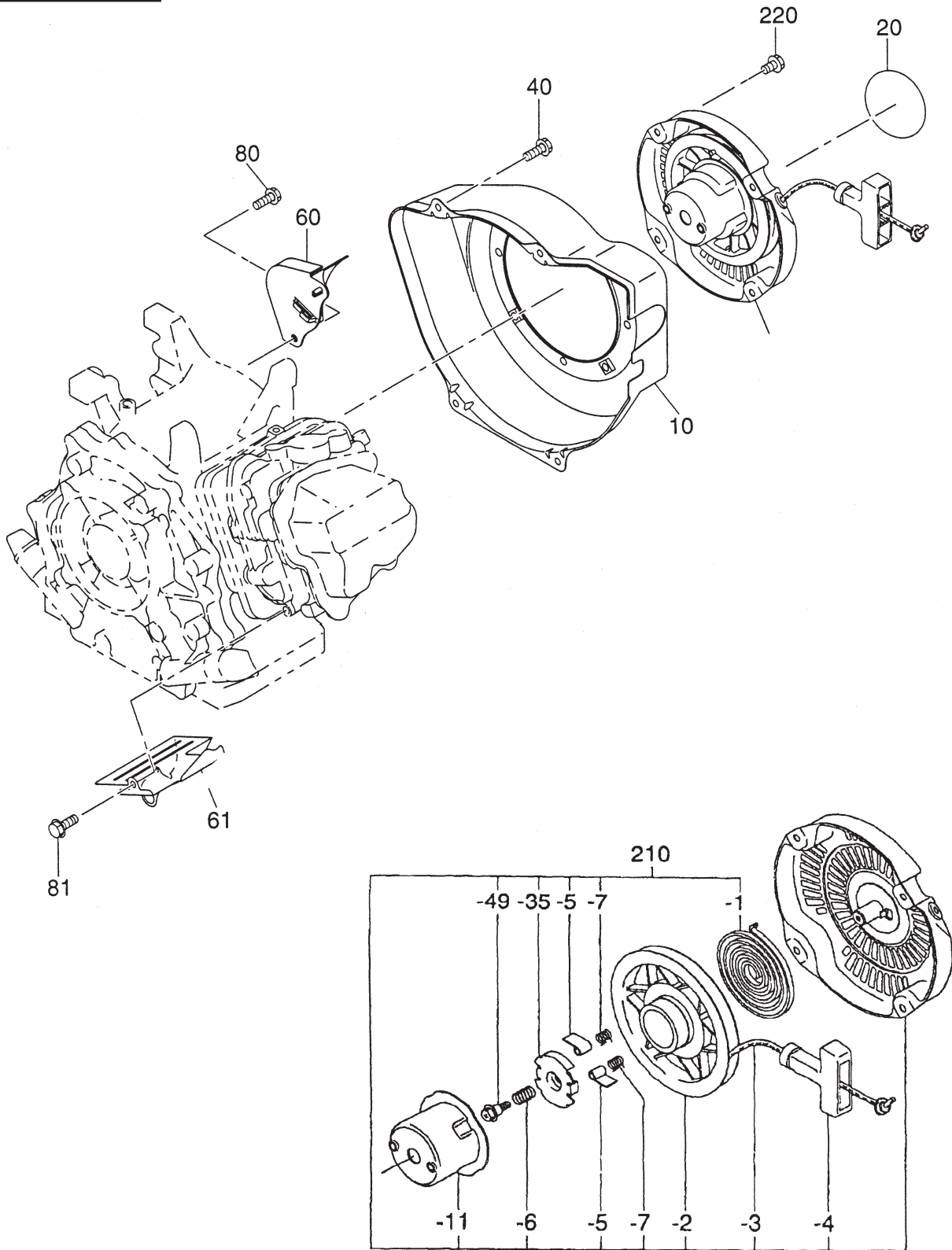

**SECTION 5 COOLING and STARTING GROUP**

REF.	PART NO.	DESCRIPTION	QTY.	REMARKS	FROM-TO	FIG.
10	279-51202-01	Blower Housing Cp	1			500
20	073-20054-70	Label, trademark	1			500
40	011-00600-30	Flange Bolt	4	Recoil		500
	011-00600-30	Flange Bolt	3	Electric Start		500
41	001-04062-00	Flange Bolt	1	Electric Start		500
60	279-52711-11	Baffle 1, case Cp	1			500
61	279-52702-13	Baffle 2, head	1			500
81	011-00600-20	Flange Bolt	1			500
220	011-00600-10	Flange Bolt	4			500
210	279-50202-00	Recoil Starter Ay	1			500
-1	226-50716-08	Spiral Spring	1			500
-2	279-50120-08	Reel	1			500
-3	279-50110-08	Starter Rope	1			500
-4	226-50701-08	Starter Knob	1			500
-5	279-50125-08	Ratchet	2			500
-6	226-50731-08	Friction Spring	1			500
-7	226-50752-08	Ratchet Spring	2			500
-8	226-50741-08	Friction Plate	1			500
-11	279-50145-08	Starter Pulley	1			500
-49	226-50753-18	Center Screw	1			500

SECTION 6 FUEL, LUBRICATION GROUP

FIG. 600

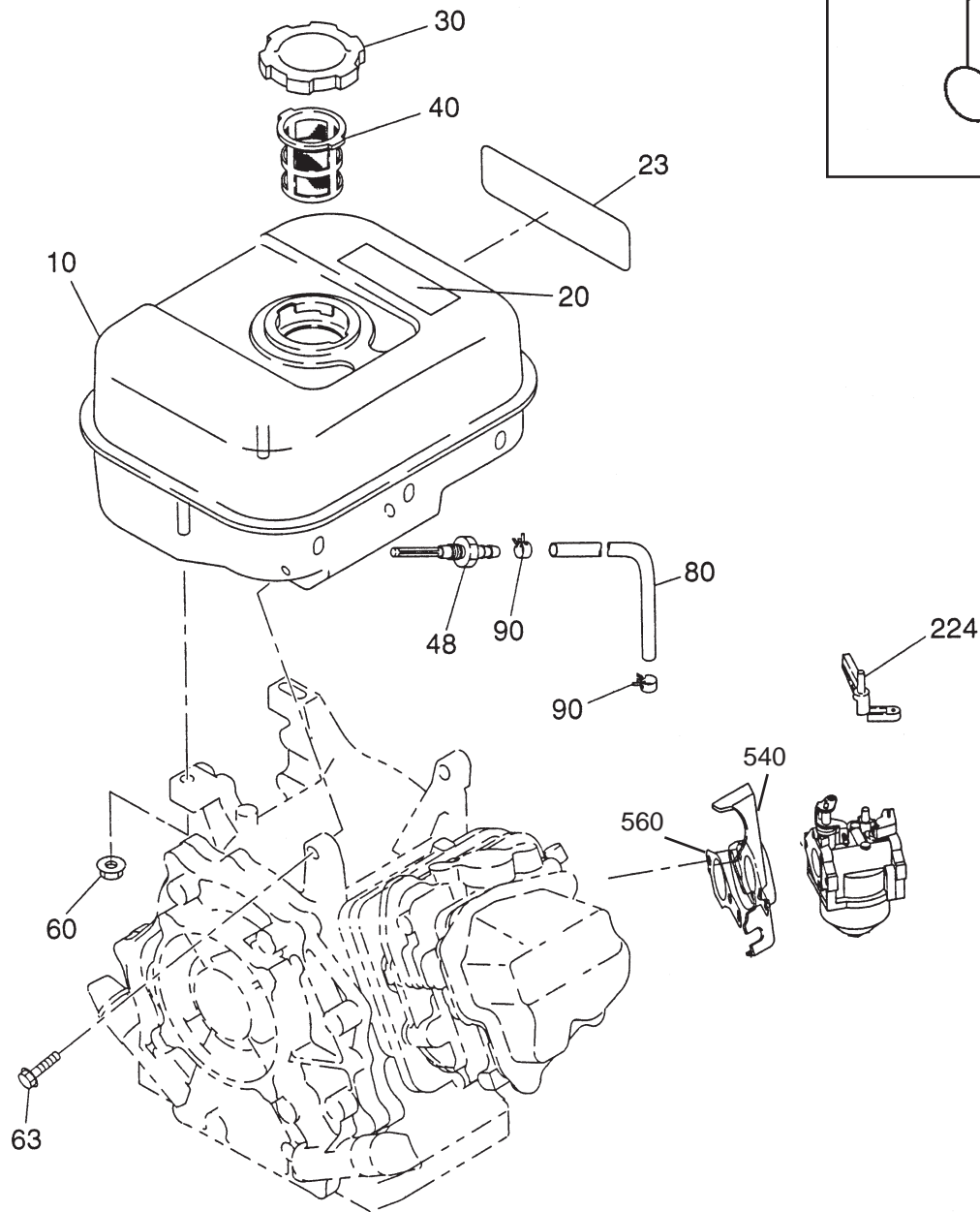

Evap Type Fuel Cap

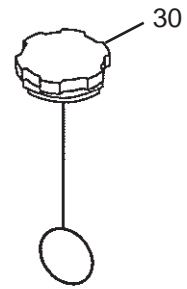
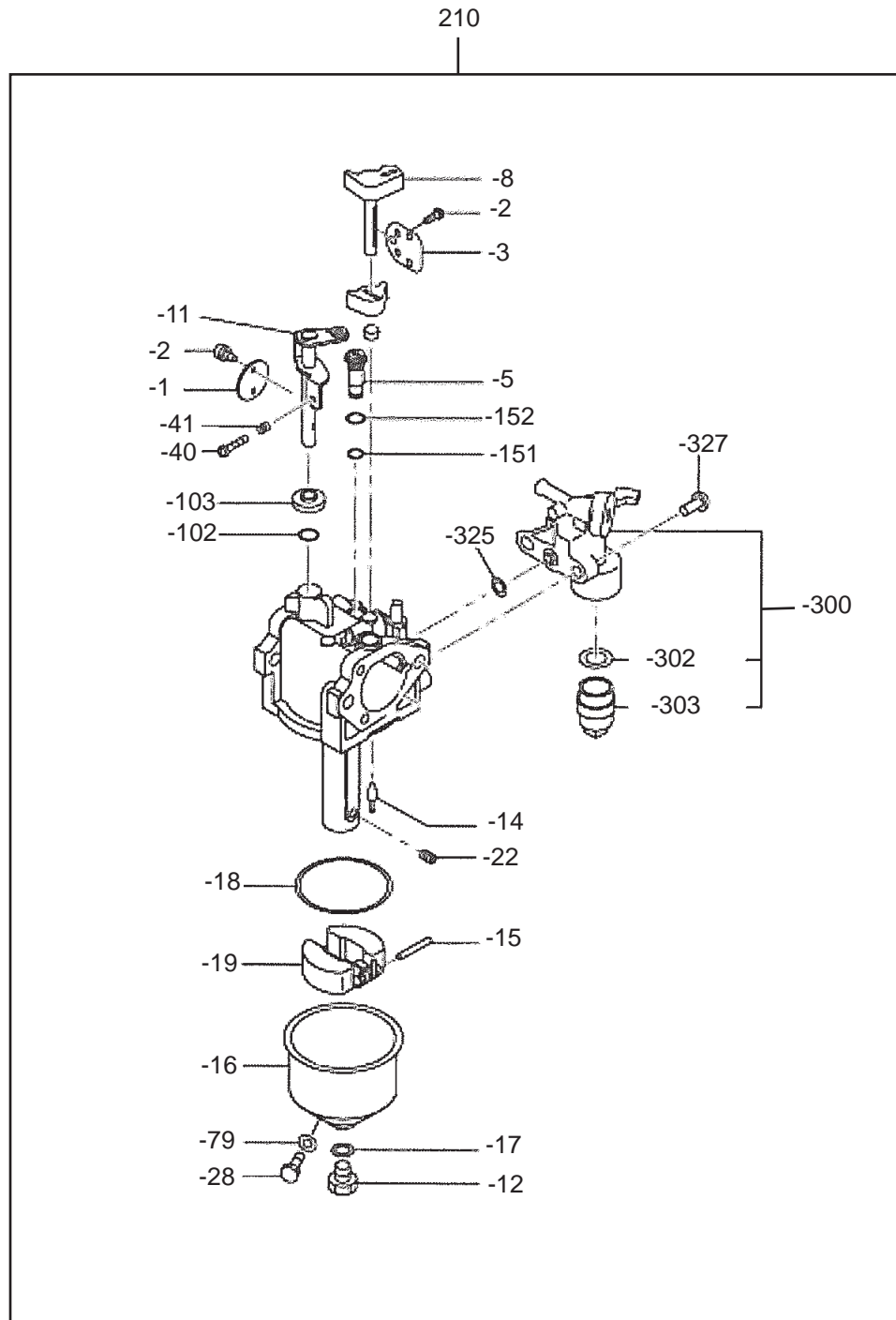





FIG. 610



**SECTION 6 CARBURETOR GROUP - FOAM, TEIKEI**

REF.	PART NO.	DESCRIPTION	QTY.	REMARKS	FROM-TO	FIG.
210	279-62301-40	Carburetor	1		~2290050	610
-1	279-62535-08	Throttle Valve	1		~2290050	610
-2	251-62450-08	Screw	2		~2290050	610
-3	279-62525-08	Choke Valve	1		~2290050	610
-5	279-62420-08	Slow Jet	1		~2290050	610
-8	279-62520-08	Choke Shaft	1		~2290050	610
-11	279-62530-08	Throttle Shaft Sub Ay	1		~2290050	610
-12	251-62453-08	Screw	1		~2290050	610
-14	279-62500-08	Needle Valve Ay	1		~2290050	610
-15	279-62515-08	Pin, float lever	1		~2290050	610
-16	285-62550-08	Float Chamber Sub Ay	1		~2290050	610
-17	251-62350-08	Gasket	1		~2290050	610
-18	279-62540-08	Gasket, chamber	1		~2290050	610
-19	279-62505-08	Float Sub Ay	1		~2290050	610
-22	279-62400-08	Main Jet	1		~2290050	610
-28	285-62551-08	Drain Screw	1		~2290050	610
-40	279-62353-18	Adjusting Screw	1		~2290050	610
-41	279-62445-08	Spring	1		~2290050	610
-79	285-62552-08	Gasket	1		~2290050	610
-102	279-62561-08	Bush	1		~2290050	610
-103	279-62562-08	Collar	1		~2290050	610
-151	279-62451-08	O ring	1		~2290050	610
-152	279-62452-08	O ring	1		~2290050	610
-300	279-62103-10	Cock Body A	1		~2290050	610
-302	277-62110-18	Packing	1		~2290050	610
-303	277-62100-18	Cup	1		~2290050	610
-325	006-26100-61	O ring	1		~2290050	610
-327	279-62585-08	Screw	2		~2290050	610

FIG. 620

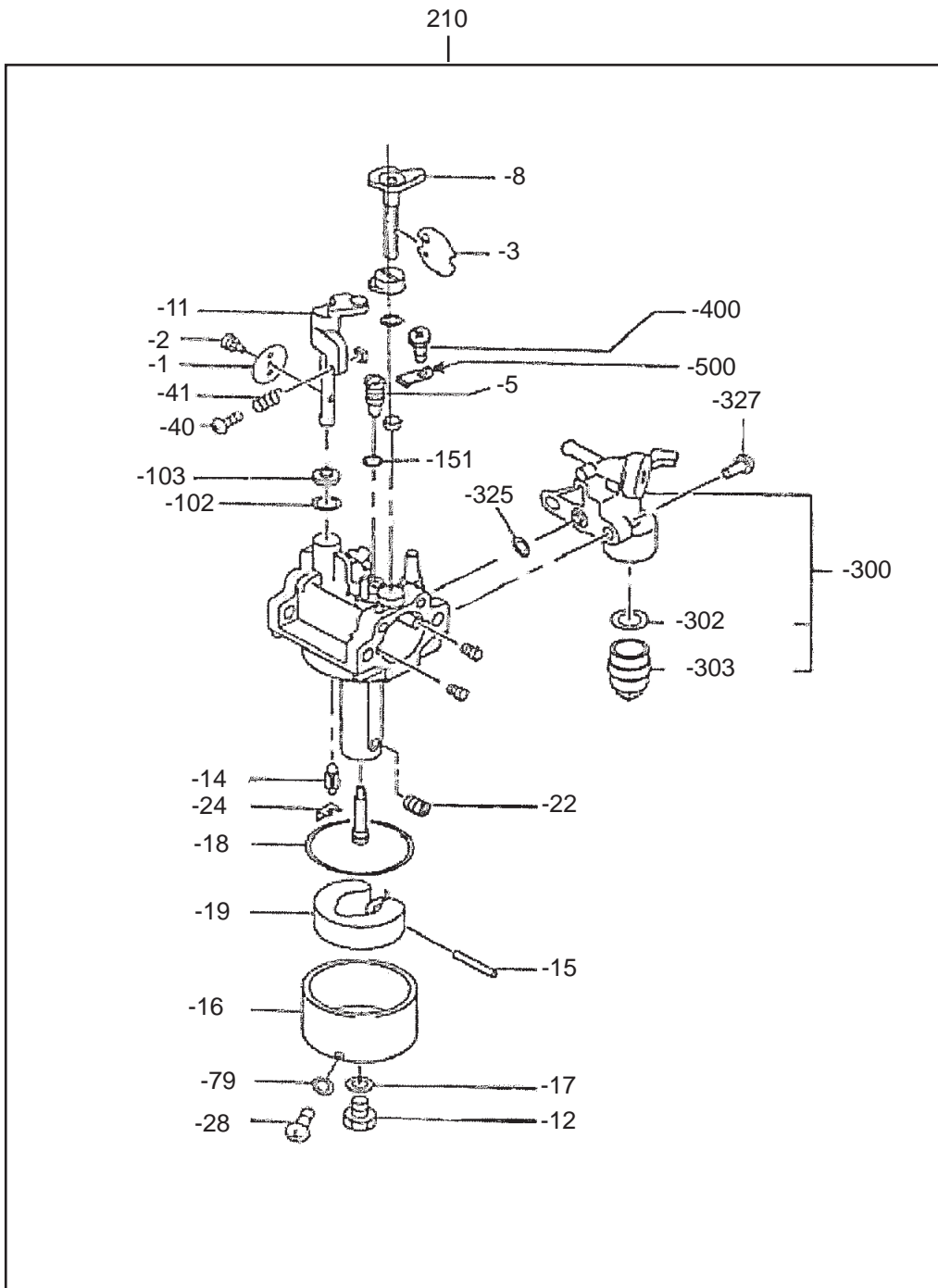

## SECTION 6      CARBURETOR GROUP - FOAM, MIKUNI

REF.	PART NO.	DESCRIPTION	QTY.	REMARKS	FROM-TO	FIG.
210	279-62361-00	Carburetor Ay	1		2290051~	620
-1	279-62536-08	Throttle Valve	1		2290051~	620
-2	209-62351-08	Screw	1		2290051~	620
-3	279-62527-08	Choke Valve	1		2290051~	620
-5	279-62421-08	Pilot Jet	1		2290051~	620
-8	279-62522-08	Choke Lever	1		2290051~	620
-11	279-62532-08	Throttle Shaft A	1		2290051~	620
-12	150-62358-08	Bolt	1		2290051~	620
-14	224-62305-08	Needle	1		2290051~	620
-15	214-62515-08	Pin	1		2290051~	620
-16	279-62506-08	Float Body Ay	1		2290051~	620
-17	207-62345-08	Packing	1		2290051~	620
-18	206-62540-08	Chamber Packing	1		2290051~	620
-19	234-62506-08	Float	1		2290051~	620
-22	279-62406-08	Main Jet	1		2290051~	620
-24	226-62701-18	Clip	1		2290051~	620
-28	279-62361-08	Bolt	1		2290051~	620
-40	106-62556-08	Screw	1		2290051~	620
-41	283-62357-08	Spring	1		2290051~	620
-79	279-62541-08	Washer	1		2290051~	620
-102	246-62390-08	Seal	1		2290051~	620
-103	279-62551-08	Ring	1		2290051~	620
-151	106-62384-08	O ring	1		2290051~	620
-300	279-62103-10	Cock Body A	1		2290051~	620
-302	277-62110-18	Packing	1		2290051~	620
-303	277-62100-18	Cup	1		2290051~	620
-325	277-62552-08	O ring	1		2290051~	620
-327	165-62377-08	Screw	2		2290051~	620
-400	279-62351-08	Screw	1		2290051~	620
-500	279-62360-08	Plate	1		2290051~	620

FIG. 630

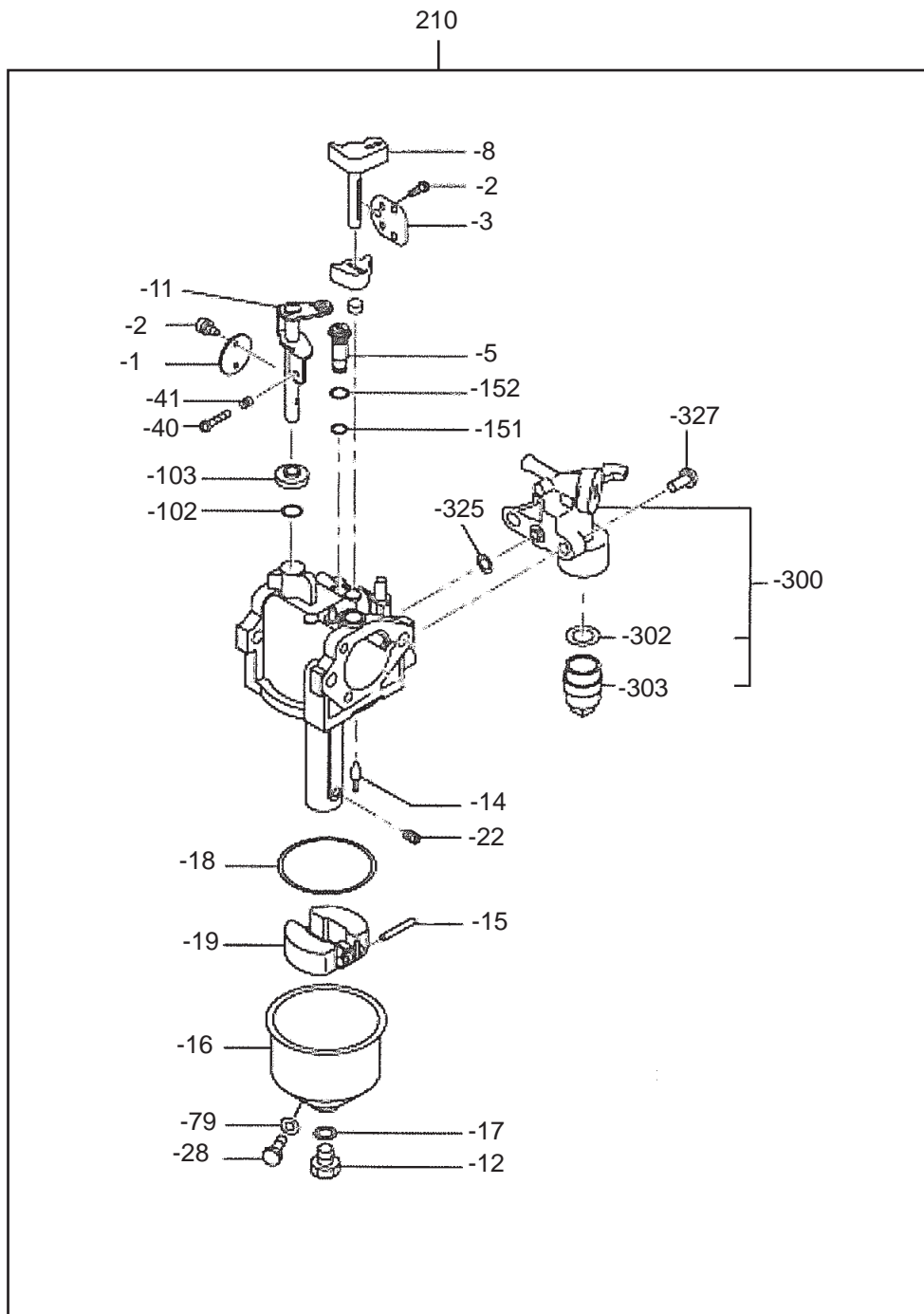

**SECTION 6 CARBURETOR GROUP - DUAL ELEMENT, TEIKEI**

REF.	PART NO.	DESCRIPTION	QTY.	REMARKS	FROM-TO	FIG.
210	279-62302-40	Carburetor Ay	1		~2316129	630
-1	279-62535-08	Throttle Valve	1		~2316129	630
-2	251-62450-08	Screw	2		~2316129	630
-3	279-62525-08	Choke Valve	1		~2316129	630
-5	279-62420-08	Slow Jet	1		~2316129	630
-8	279-62520-08	Choke Shaft	1		~2316129	630
-11	279-62530-08	Throttle Shaft Sub Ay	1		~2316129	630
-12	251-62453-08	Screw	1		~2316129	630
-14	279-62500-08	Needle Valve Ay	1		~2316129	630
-15	279-62515-08	Pin, float lever	1		~2316129	630
-16	285-62550-08	Float Chamber Sub Ay	1		~2316129	630
-17	251-62350-08	Gasket	1		~2316129	630
-18	279-62540-08	Gasket, chamber	1		~2316129	630
-19	279-62505-08	Float Sub Ay	1		~2316129	630
-21	279-62401-08	Main Jet	1		~2316129	630
-28	285-62551-08	Drain Screw	1		~2316129	630
-40	279-62353-18	Adjusting Screw	1		~2316129	630
-41	279-62445-08	Spring	1		~2316129	630
-79	285-62552-08	Gasket	1		~2316129	630
-102	279-62561-08	Bush	1		~2316129	630
-103	279-62562-08	Collar	1		~2316129	630
-151	279-62451-08	O ring	1		~2316129	630
-152	279-62452-08	O ring	1		~2316129	630
-300	279-62103-10	Cock Body A	1		~2316129	630
-302	277-62110-18	Packing	1		~2316129	630
-303	277-62100-18	Cup	1		~2316129	630
-325	006-26100-61	O ring	1		~2316129	630
-327	279-62585-08	Screw	1		~2316129	630

FIG. 640

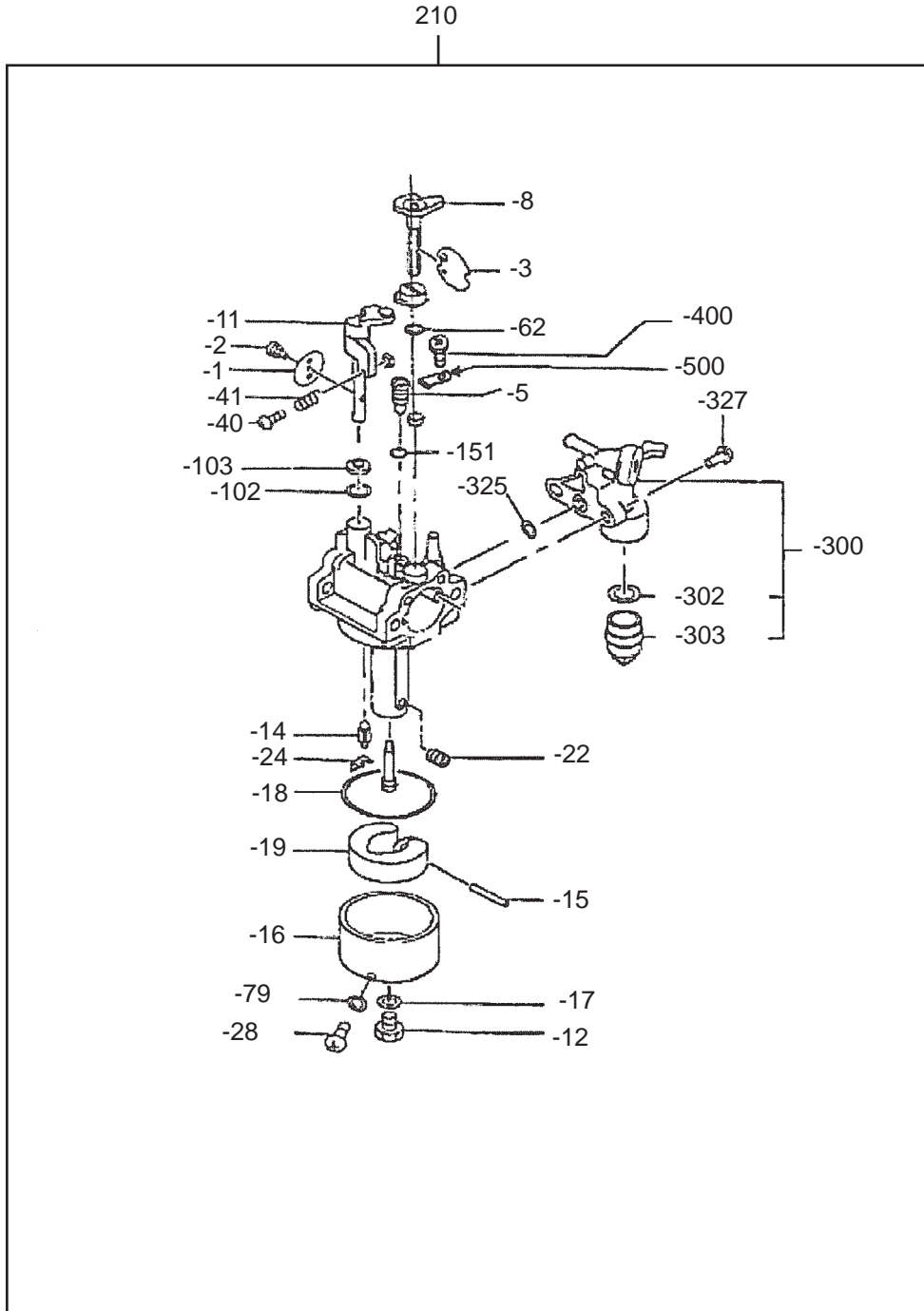



**SECTION 6 CARBURETOR GROUP - DUAL, PRE-CLEANER, MIKUNI**

<b>REF.</b>	<b>PART NO.</b>	<b>DESCRIPTION</b>	<b>QTY.</b>	<b>REMARKS</b>	<b>FROM-TO</b>	<b>FIG.</b>
210	279-62363-00	Carburetor Ay	1		2316130~	640
-1	279-62536-08	Throttle Valve	1		2316130~	640
-2	209-62351-08	Screw	2		2316130~	640
-3	279-62527-08	Choke Valve	1		2316130~	640
-5	279-62422-08	Pilot Jet	1		2316130~	640
-8	279-62522-08	Choke Shaft	1		2316130~	640
11	279-62533-08	Throttle Shaft	1		2316130~	640
-12	150-62358-08	Bolt	1		2316130~	640
-14	224-62305-08	Needle Valve	1		2316130~	640
-15	214-62515-08	Pin	1		2316130~	640
-16	279-62506-08	Chamber	1		2316130~	640
-17	207-62345-08	Gasket	1		2316130~	640
-18	206-62540-08	Chamber Packing	1		2316130~	640
-19	234-62506-08	Float Ay	1		2316130~	640
-22	279-62409-08	Main Jet	1		2316130~	640
-24	226-62701-18	Clip	1		2316130~	640
-28	279-62361-08	Bolt	1		2316130~	640
-40	106-62556-08	Screw	1		2316130~	640
-41	283-62357-08	Spring	1		2316130~	640
-62	236-62680-08	Seal	1		2316130~	640
-79	279-62541-08	Washer	1		2316130~	640
-102	246-62390-08	Seal	1		2316130~	640
-103	279-62551-08	Ring	1		2316130~	640
-151	106-62384-08	O ring	1		2316130~	640
-300	279-62103-10	Cock Body Ay	1		2316130~	640
-302	277-62110-18	Packing	1		2316130~	640
-303	277-62100-18	Cup	1		2316130~	640
-325	277-62552-08	O ring	1		2316130~	640
-327	165-62377-08	Screw	2		2316130~	640
-400	279-62351-08	Screw	1		2316130~	640
-500	279-62360-08	Plate	1		2316130~	640

FIG. 650

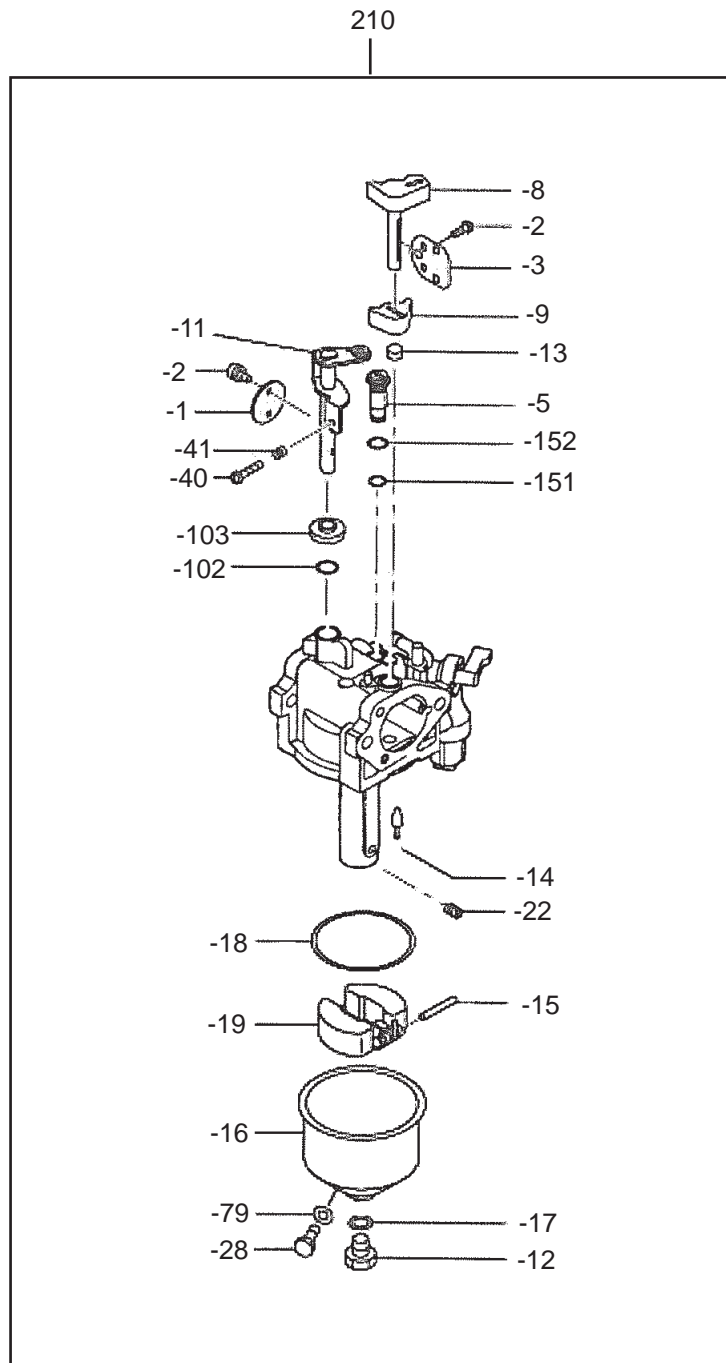

**SECTION 6 CARBURETOR GROUP - LOW PROFILE, TEIKEI**

REF.	PART NO.	DESCRIPTION	QTY.	REMARKS	FROM-TO	FIG.
210	279-62304-20	Carburetor Ay	1		~2275957	650
-1	279-62535-08	Throttle Valve	1		~2275957	650
-2	251-62450-08	Screw	2		~2275957	650
-3	279-62526-08	Choke Valve	1		~2275957	650
-5	279-62420-08	Slow Jet	1		~2275957	650
-8	279-62570-08	Choke Shaft	1		~2275957	650
-11	279-62530-08	Throttle Shaft	1		~2275957	650
-12	251-62453-08	Screw	1		~2275957	650
-14	279-62500-08	Needle Valve Ay	1		~2275957	650
-15	279-62515-08	Pin, float lever	1		~2275957	650
-16	279-62550-08	Float Body	1		~2275957	650
-17	251-62350-08	Gasket	1		~2275957	650
-18	279-62540-08	Gasket, chamber	1		~2275957	650
-19	279-62550-08	Float, chamber	1		~2275957	650
-22	279-62400-08	Main Jet	1		~2275957	650
-28	279-62355-08	Drain Screw	1		~2275957	650
-40	279-62353-08	Adjust Screw	1		~2275957	650
-41	279-62445-08	Spring	1		~2275957	650
-79	279-62552-08	Gasket	1		~2275957	650
-102	279-62562-08	Collar	1		~2275957	650
-103	279-62561-08	Bushing	1		~2275957	650
-151	279-62452-08	O ring	1		~2275957	650
-152	279-62451-08	O ring	1		~2275957	650
-302	064-20064-10	Packing	1		~2275957	650
-303	064-20078-10	Cup	1		~2275957	650
*	279-62536-08	Collar, upper	1		~2275957	650
*	279-62564-08	Collar, lower	1		~2275957	650

FIG. 660

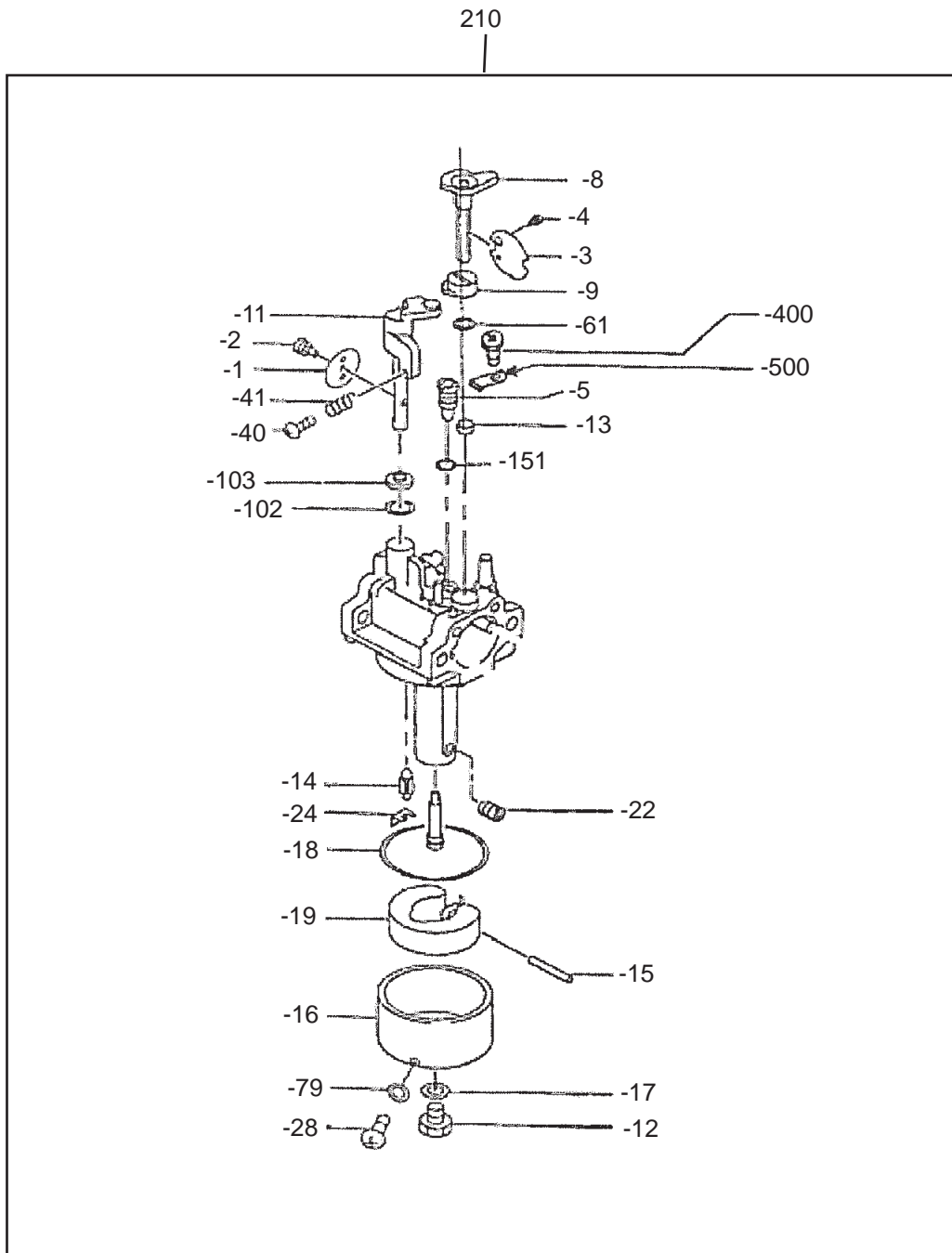



# SECTION 7 ELECTRIC DEVICE GROUP

## FIG. 700

For 200 Watt  
Charging

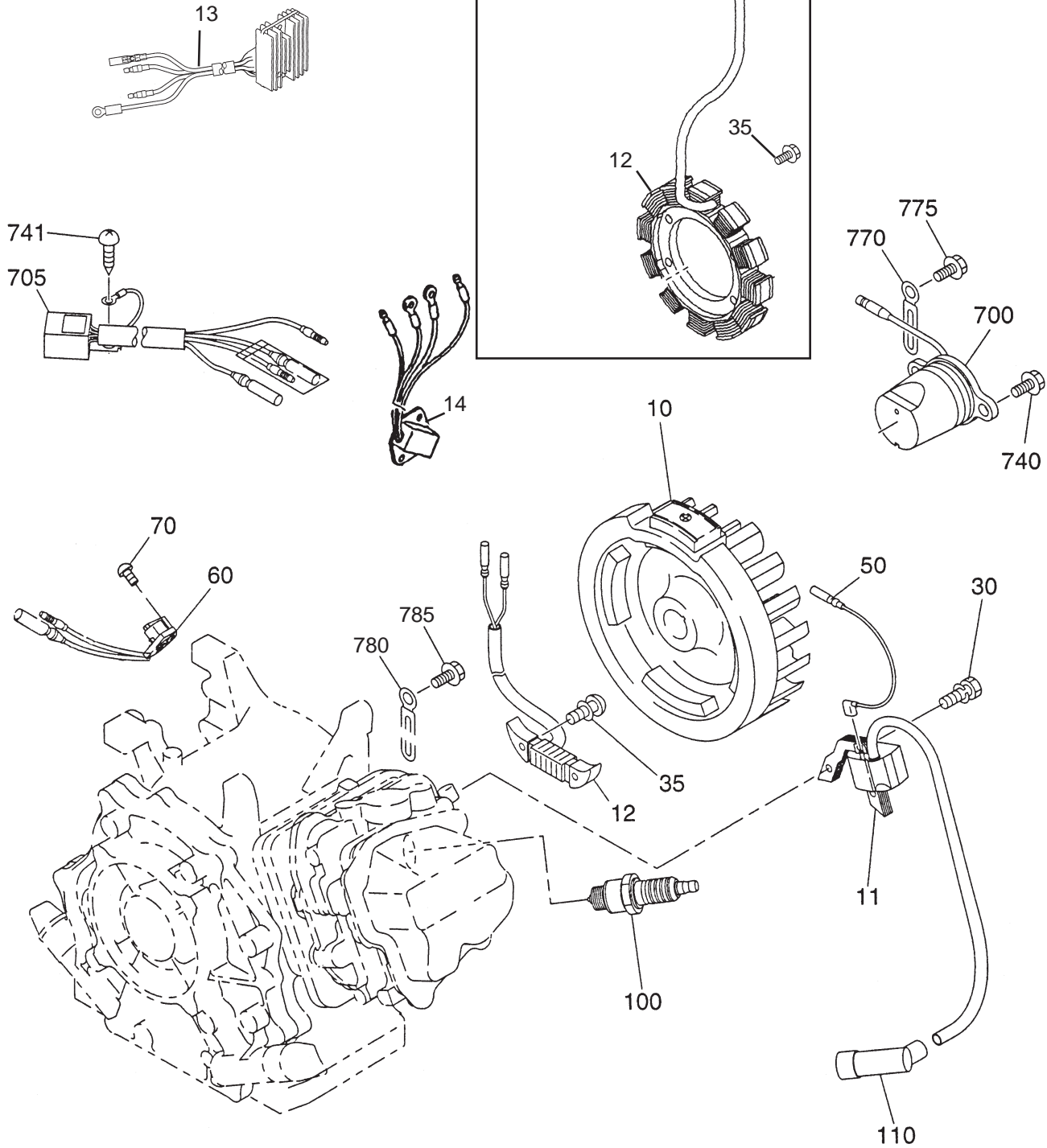

**SECTION 7 ELECTRIC DEVICE GROUP**

REF.	PART NO.	DESCRIPTION	QTY.	REMARKS	FROM-TO	FIG.
10	279-79231-01	Flywheel Cp	1	Std	7061~	700
	279-79230-11	Flywheel Cp	1	Std	~7060	700
10	279-79251-01	Flywheel Cp	1	15 W, 40 W w/ ring gear		700
	279-79241-01	Flywheel Cp	1	15 W, 40 W w/o ring gear		700
	279-79252-01	Flywheel Cp	1	200 W w/ ring gear		700
	279-79242-01	Flywheel Cp	1	200 W w/o ring gear		700
11	279-79430-01	Ignition Coil Cp	1			700
12	279-79301-01	Lamp Coil Cp	1	15 W		700
	279-79302-01	Lamp Coil Cp	1	40 W		700
	279-79303-11	Charge Coil	1	200 W		700
20	267-71002-03	Ring Gear	1			700
30	001-14062-50	Bolt and Washer Ay	2			700
35	001-13062-00	Bolt and Washer Ay	2	15 W, 40 W		700
	004-35062-50	Bolt and Washer Ay	4	200 W		700
50	277-73101-H1	Wire 1 Cp	1			700
	279-73105-H1	Wire 5 Cp	1	Electric Start		700
60	X66-00004-20	Switch Ay	1			700
70	015-00400-90	Tapping Screw	2			700
100	065-01401-50	Spark Plug	1			700
110	065-50002-70	Spark Plug Cap	1			700
700	279-76301-41	Oil Sensor Cp	1			700
705	KU3-11043-11	Control Unit	1			700
733	277-75801-03	Shield Plate	1	Electric Start / 200 W		700
740	001-14061-60	Bolt and Washer Ay	2			700
	013-00602-60	Bolt and Washer Ay	2	Electric Start / 200 W		700
741	011-00600-10	Flange Bolt	1			700
770	279-75501-13	Wire Clamp	1			700

SECTION 7 ELECTRIC DEVICE GROUP - CONTROL BOX

FIG. 710

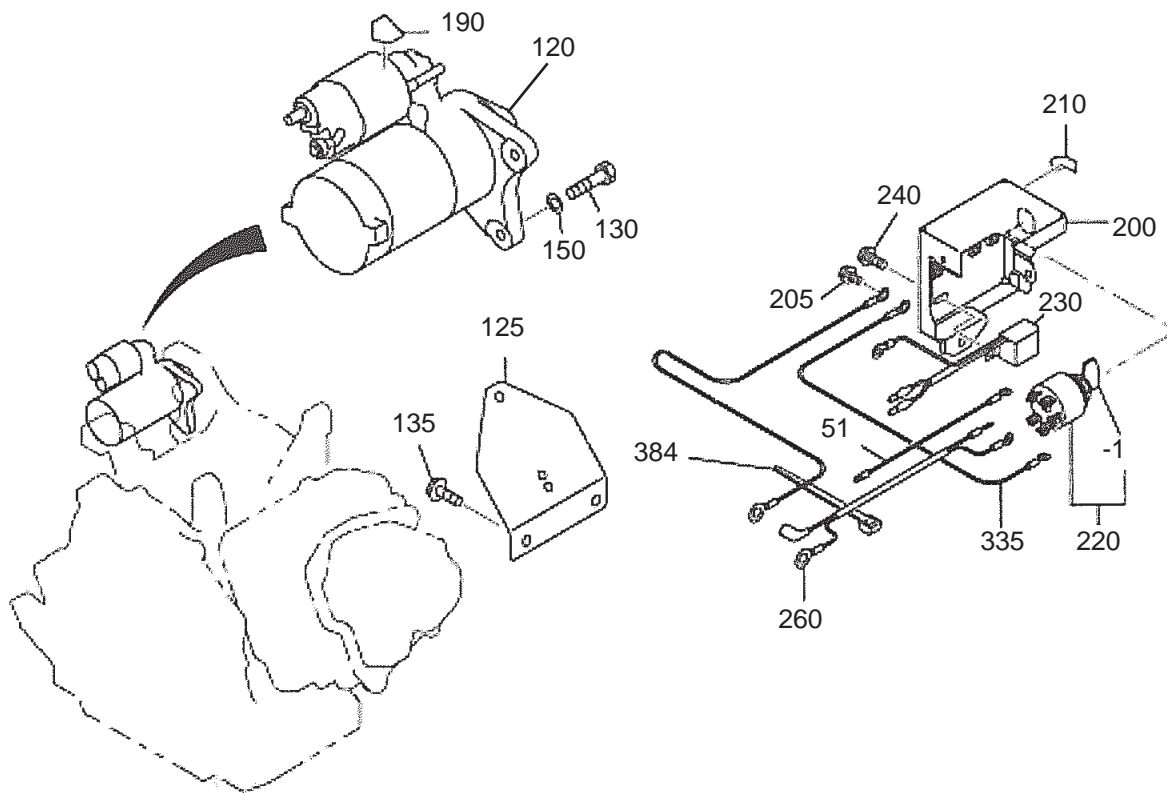
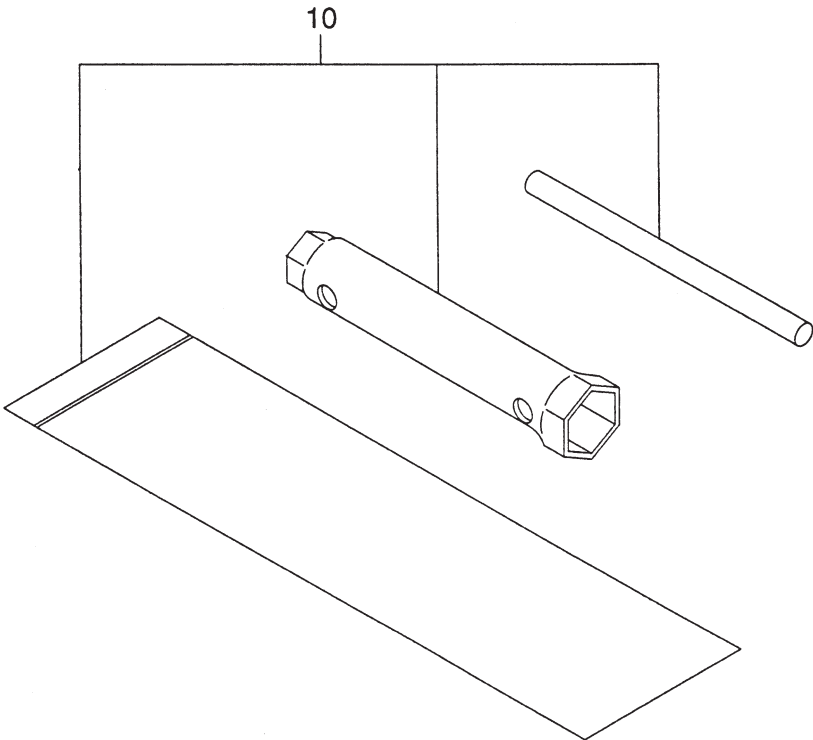





FIG. 900





PRINTED IN THE USA